



SOCIETÀ PER L'ELETTRONICA s.r.l.

EXPERT 1K-FA

1KW SOLID STATE FULLY AUTOMATIC LINEAR AMPLIFIER

USER'S MANUAL



**THIRD SERIES
CERTIFIED CE/FCC**

Main index

IMPORTANT	5
PRECAUTIONS.....	5
UNPACKING	8
1. PANEL DESCRIPTION	9
1.1 Front Panel	9
1.2 Rear Panel.....	10
2. GENERAL INFORMATION	11
2.1 Power supply	11
2.2 Input / Output.....	11
2.3 ALC / RELAY / CAT.....	11
3. INTERCONNECTION WITH THE TRANSCEIVER	13
4. USE OF THE LINEAR AMPLIFIER.....	14
4.1 SO2R (Single Operator Two Radio).....	15
5. EXTERNAL GROUND CONNECTION	16
6. ANTENNA.....	16
7. POWER SUPPLY	17
7.1 Mains cable termination.....	17
8. TUNER	20
9. PROTECTIONS / ALARMS.....	21
10. PROGRAMMING.....	23
10.1 Ways to operate	23
11. INITIAL OPERATION OF THE AMPLIFIER.....	26
11.1 Initial Programming.....	26
11.2 Operating	28
12. CAT CONNECTIONS.....	30
12.1 CAT Connector.....	30
12.2 SPE.....	30
12.3 ICOM	31
CAT CI-V Interface	31
BAND CONTROL VOLTAGE Interface.....	31
12.4 KENWOOD.....	32
CAT RS232 Interface	32
CAT 5V TTL Interface.....	32
12.5 YAESU.....	33
CAT RS232 Interface	33
CAT 5V TTL Interface.....	33
BAND DATA Interface	34
12.6 TEN-TEC, FlexRadio, ELECRAFT	34
CAT RS232 Interface	34
12.7 TRANSCEIVERS OF OTHER BRANDS.....	35
13. OTHER CONNECTIONS	36
13.1 ALC, RELAY CONNECTIONS	36
13.2 REMOTE ON LINK.....	36
13.3 TX INH LINK.....	37
14. TRANSCEIVER CONTROLLED WITH A PC.....	38
14.1 ICOM CI-V INTERFACE.....	38
14.2 RS232 INTERFACE	39
14.3 5V TTL KENWOOD INTERFACE	39
14.4 5V TTL YAESU INTERFACE	40
15. USE OF THE RS-232 PORT.....	41
16. MAINTENANCE	42
17. CHARACTERISTICS / SPECIFICATIONS	43

18.	APPENDIX 1.....	45
18.1	Main Display Page (STANDBY Mode).....	45
18.2	Main Display Page (TX Exciter).....	46
18.3	Alarm History Display Page.....	47
18.4	Setup Options Menu.....	48
18.5	SET ANTENNA Menu.....	50
18.6	SET CAT Menu.....	52
18.7	SPE CAT Settings.....	54
18.8	ICOM CAT Settings.....	54
18.9	KENWOOD, ELECRAFT CAT Settings.....	55
18.10	YAESU CAT Settings.....	55
18.11	TEN-TEC CAT Settings.....	56
18.12	FLEX-RADIO CAT Settings.....	56
18.13	RS-232 CAT Settings.....	57
18.14	NO CAT Settings.....	57
18.15	MANUAL TUNE Display Page.....	59
18.16	BACKLIGHT Display Page.....	61
18.17	CONTEST Settings.....	62
18.18	BEEP Settings.....	63
18.19	START Settings.....	64
18.20	TEMP Settings.....	65
18.21	OPERATE Mode.....	66
18.22	OPERATE Mode and FLEX-RADIO CAT interface.....	68
18.23	Diagnostics.....	70
19.	TABLE.....	72
20.	WARRANTY.....	73
	SPACE FOR THE REPAIRER.....	74

Congratulations for choosing the SPE EXPERT 1K-FA linear amplifier: It is small, and powerful, it covers the whole frequency range from 1.8 to 54 MHz, completely automatically. All operating conditions (frequency, antenna and tuner) may be controlled from your transceiver. It is possible to connect it to every type of device, it is extremely user-friendly, and offers a product which is best-in-class.

IMPORTANT

Read this instruction manual carefully before attempting to operate the linear amplifier.

The warranty will be invalidated in the case of non-observance of these instructions.

Keep this manual. It contains important safety and operating instructions for the SPE EXPERT 1K-FA.

This manual may be subject to changes and updates therefore please refer always to the updated version available on the website www.linear-amplifier.com. If in doubt, refer to the interpretation in English version.

PRECAUTIONS

Explicit definitions

WORD	DEFINITION
 WARNING!	Risk of danger of fire or electric shock to persons. Possible damage to the amplifier.
NOTE:	Serious problems if not observed. Danger of fire or electric shock for the operator, or damage to the equipment.

WARNING!

HIGH VOLTAGE! DO NOT disconnect an antenna from the amplifier during transmission; electric shock or fire is possible.

WARNING!

DO NOT modify the internal wiring of the amplifier. Any modifications will invalidate the warranty, and may reduce the performance of the linear amplifier or damage it.

WARNING!

Before using the linear amplifier, compare the value of voltage of the local mains supply network with the value required by the amplifier, and set it up correctly.

WARNING!

DO NOT turn ON the linear amplifier unless it has been properly grounded through the green/yellow conductor of the mains cord. Your dealer will already have provided the correct mains plug for your local electricity network, with the earth pin connected to that conductor. Do not disconnect this under any circumstances, or there is a risk of severe or fatal electric shock.

WARNING!

DO NOT use an extension cord with the AC power cable, as if it is not correctly rated there is a risk of fire or electric shock.

 **WARNING!**

DO NOT allow metallic objects or wires to enter inside the amplifier.

 **WARNING!**

DO NOT obstruct the entries for cooling air at both the sides of the amplifier. Ensure that no object impedes the correct operation of the fans.

 **WARNING!**

DO NOT expose the linear amplifier to rain, snow or any liquids.

 **WARNING!**

DO NOT instal the linear amplifier in a place without good ventilation. This could limit heat dissipation and the amplifier could be damaged.

 **WARNING!**

DO NOT touch the amplifier with damp or wet hands. There is danger of electric shock. Avoid opening it before you have disconnected it from the mains supply, then wait at least 2 minutes for electrolytic capacitors to complete their discharge.

To clean the amplifier **DO NOT** use chemical agents like alcohol or benzene because the plastic surfaces could be damaged.

AVOID using the amplifier in areas with temperatures below -10°C ($+14^{\circ}\text{F}$) or above $+40^{\circ}\text{C}$ ($+104^{\circ}\text{F}$).

AVOID using the linear amplifier in locations that are very dusty, damp or in direct sunlight.

AVOID placing the linear amplifier against walls, the circulation of the air would be obstructed and the noise of the fans would be reflected toward the operator.

AVOID permitting children to play with the amplifier.

If you do not use the linear amplifier for long time, set the back main switch [I/O] to the OFF position [O].

This amplifier should only be operated by persons who have an appropriate radio transmitting licence, and you should observe your licence conditions whilst using it.

UNPACKING

Remove the packing and carefully check the contents.
If you find any damage or if there are any parts missing, contact your retailer immediately.

Keep the shipping cartons for future transportation if required.

Accessories included in the carton

- a) Transport carry bag.
- b) 2 - cables with RCA (phono) connectors for ALC, RELAY links.
- c) 1 - standard RS232 cable.
- d) 2 -15 pole connectors (DB-15) for CAT links.
- e) User manual.
- f) Spare fuses:
 - 1 - 12.5 A.
 - 1 - 0,5 A.
 - 1 - 20 A
 - 1 - 20 A (USA and Japan only).
 - 1 - 1 A. (USA and Japan only).
- g) Spare air filter.
- h) Certificate of compliance and warranty form.

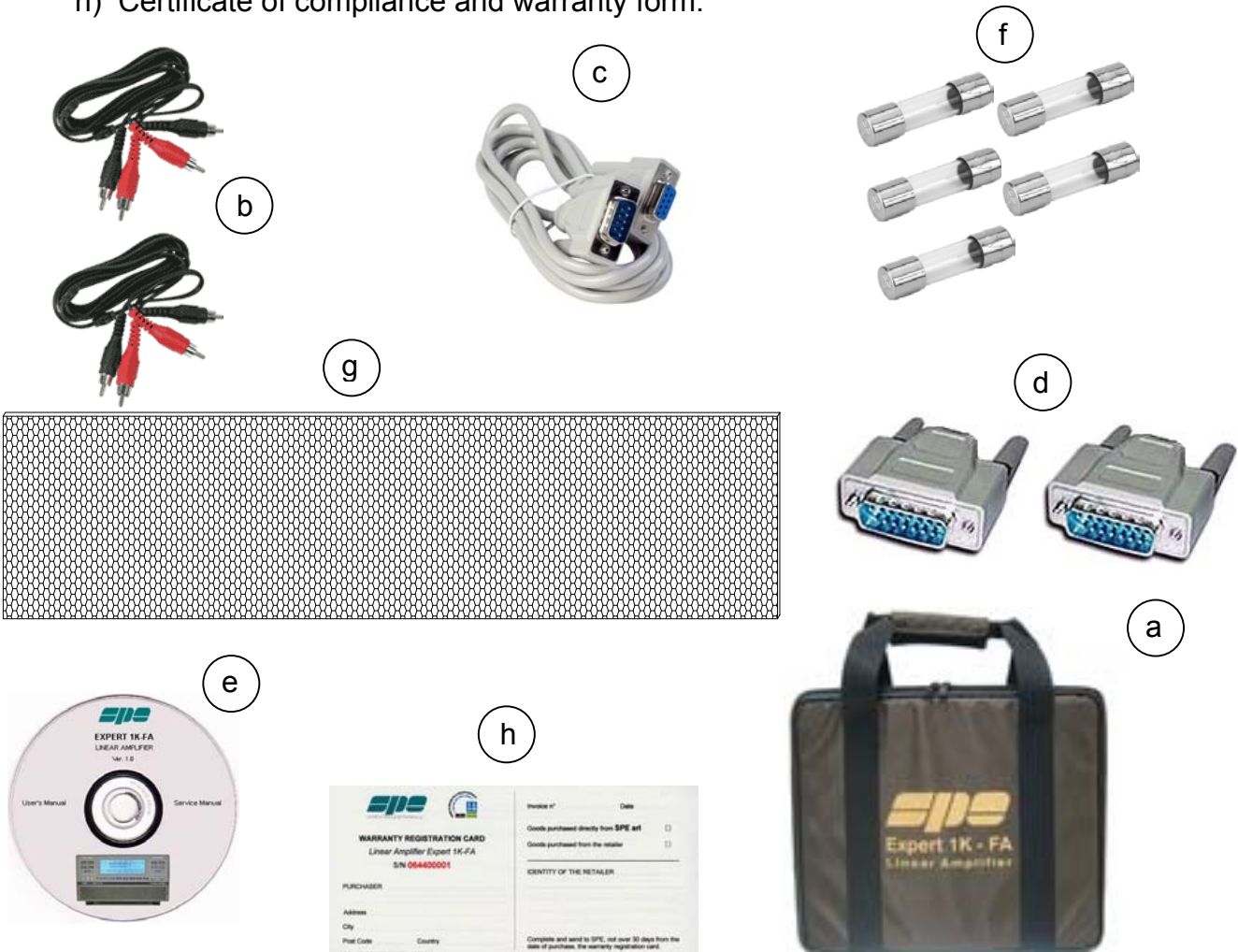

1. PANEL DESCRIPTION

1.1 Front Panel

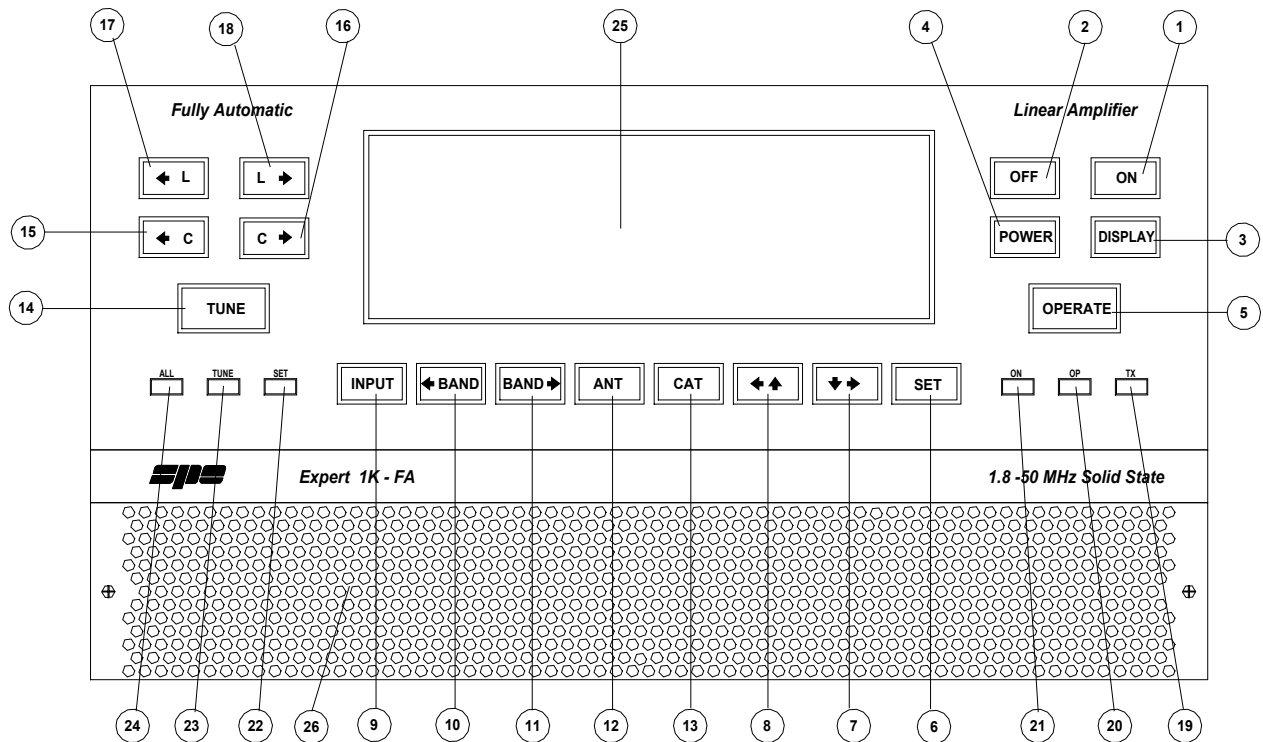

- 1) ON
- 2) OFF
- 3) DISPLAY switches between display pages.
- 4) POWER switches output power from "FULL / HALF" (1KW / 500 W).
- 5) OPERATE switches between Standby / Operate.
- 6) SET used to program the amplifier.
- 7) ▼► used to program the amplifier.
- 8) ◀▲ used to program the amplifier.
- 9) INPUT selects one of the two inputs of the amplifier.
- 10) ◀BAND switches bands manually (downward in frequency).
- 11) BAND► switches bands manually (upward in frequency).
- 12) ANT switches the antennas for every single band
- 13) CAT shows the current CAT interface setting.
- 14) TUNE: starts the automatic tuning process.
- 15) ◀C used for manual tuning.
- 16) C► used for manual tuning.
- 17) ◀L used for manual tuning.
- 18) L► used for manual tuning.
- 19) TX red led, illuminates during transmission.
- 20) OP yellow led, illuminates when the amplifier is in "Operate" state.
- 21) ON green led, illuminates when the amplifier is "ON".
- 22) SET green led, illuminates during programming.
- 23) TUNE yellow led, illuminates during tuning.
- 24) ALL red led, illuminates when there is an alarm.
- 25) DISPLAY
- 26) AIRFLOW GRID

1.2 Rear Panel

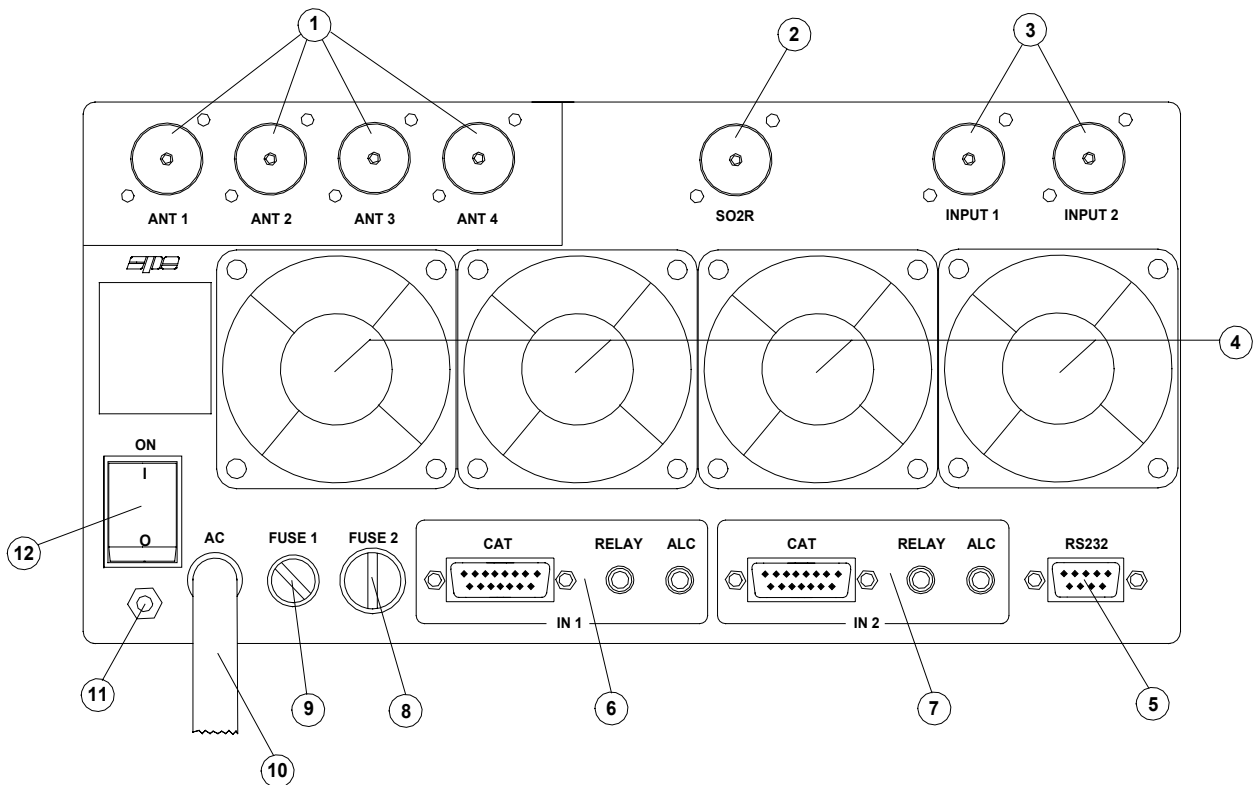

- | | |
|---------------------|---|
| 1) ANT | connectors for four possible antennas. |
| 2) SO2R | connector for SO2R operations |
| 3) INPUT | connectors to connect two exciters. |
| 4) FANS | |
| 5) RS 232 CONNECTOR | |
| 6) IN 1 | ALC, RELAY, CAT connectors for exciter 1. |
| 7) IN 2 | ALC, RELAY, CAT connectors for exciter 2. |
| 8) FUSE 2 | fuse for the power supply; PA unit 12.5A (230, 215, 200 Vac), 20A (115, 100 Vac). |
| 9) FUSE 1 | fuse for the power supply; electronic unit 0.5A (230, 215, 200 Vac), 1A (115, 100 Vac). |
| 10) AC | mains power cable. |
| 11) GND | ground connector. |
| 12) ON | main switch. |

2. GENERAL INFORMATION

(Read the specific chapters for more details).

2.1 Power supply

The amplifier's power supply is 230, 215, 200, 115, 100 Vac (230 Vac default).

The main switch [I/O] is located on the rear panel, in the [O] position all the internal circuitry is powered off, in the [I] position (red led ON) it is possible to turn ON or turn OFF the linear amplifier in one of the following ways:

- a) Using the [ON]/[OFF] keys on the front panel.
- b) Applying / removing 9 -15 Vdc on pin (8) of the CAT connector.
- c) Using the RS232 port and the management software. It is possible to download this software from the website www.linear-amplifier.com .

Note: when turned ON, almost all transceivers output 13,8 Vdc. With this voltage, the linear amplifier can be turned automatically ON / OFF at the same time as the transceiver.

2.2 Input / Output

The linear amplifier has two inputs (INPUT 1, INPUT 2) to which it is possible to connect two transceivers of any brand or type. These inputs are selected with the [INPUT] key.

It can manage up to four antennas (ANT 1, ANT 2, ANT 3, ANT 4).

The amplifier selects antennas automatically when they have been programmed.

The SO2R functionality is implemented using its proper connector.

2.3 ALC / RELAY / CAT

There are two transceiver inputs (IN 1, IN 2), to allow two different transceivers to be connected at the same time.

ALC Is a voltage (0, -11 Vcc) generated by the amplifier, it is used to control the output power of the transceiver. In this way the power from the amplifier may be automatically controlled. This link is recommended.

If the ALC port is not connected, it is necessary to manually regulate the drive power from the transceiver.

RELAY This essential link allows the amplifier to be put in the transmit state. To do that it is necessary that the inner pin of the phono connector is connected to signal ground. This is normally done at the transceiver with either a close on ground relay, or with a switching transistor. It is important that the voltages at that terminal do not exceed 12 Vdc. On the transceiver this link is often called SEND or TX GND. Refer to your transceiver manual for more details.

CAT Thanks to this link the linear amplifier will detect the operating frequency of the transceiver and then automatically control changes of band, antenna and automatic antenna tuner. Most modern transceivers have CAT control. In old models often, analog or digital information are sent for changing band. The SPE Expert 1K-FA, thanks to an efficient frequency counter, constantly

controls and verifies data coming from the transceiver. Automatic management of bands, antennas and tuner can be done in the following way:

- a) In all recent transceivers through CAT connection.
- b) In the older ICOM models, through "BAND CONTROL VOLTAGE".
- c) In the YAESU models not listed, or without CAT, through "BAND DATA".
- d) In every other case through the internal frequency counter.

Note: in case d) the CAT link with the transceiver is not needed because the frequency is detected from the transmitted signal.

Note: in some transceivers the "RELAY" and "CAT" signals are activated by menu selection: refer in this case to their proper user's manuals.

3. INTERCONNECTION WITH THE TRANSCEIVER

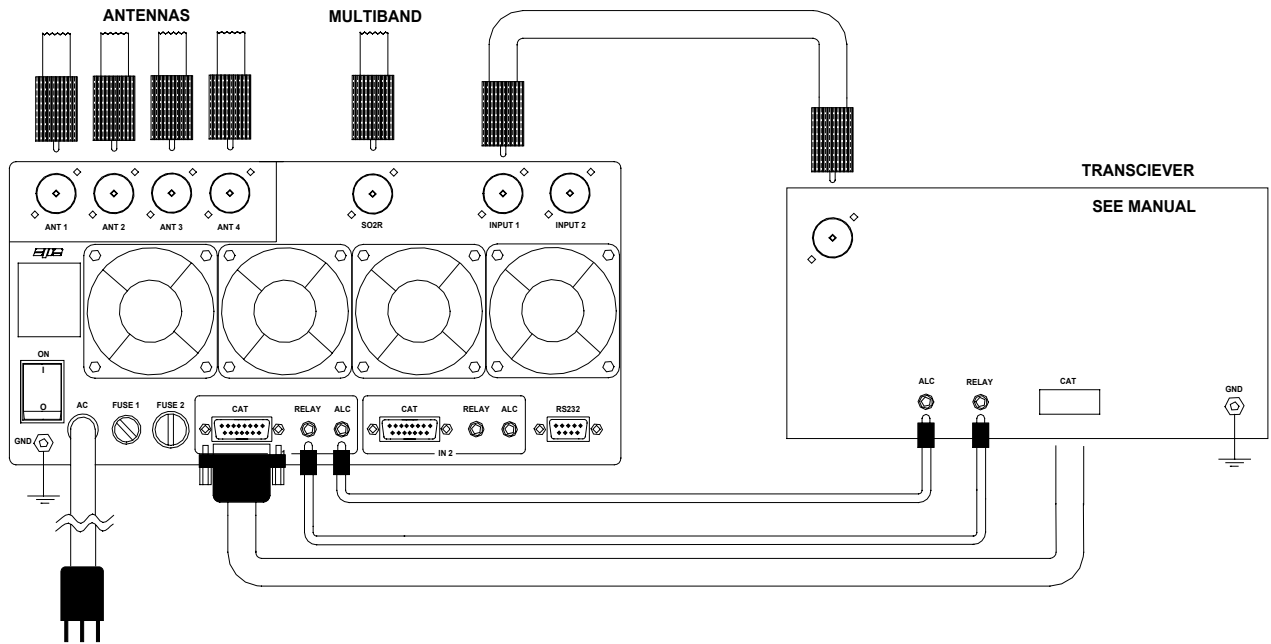

The diagram shows the connections with one transceiver only. To connect the second transceiver repeat the same connections using the port "IN 2".

For the ALC, RELAY connections, use the shielded cable (furnished) with phono RCA connectors.

For the CAT connection, the cable must be made for the transceiver to be connected. This cable may also be made to include ALC, RELAY ON / OFF (read the "CAT CONNECTIONS" chapter of this manual).

For all other information about connecting a transceiver, please refer to its manual.

4. USE OF THE LINEAR AMPLIFIER

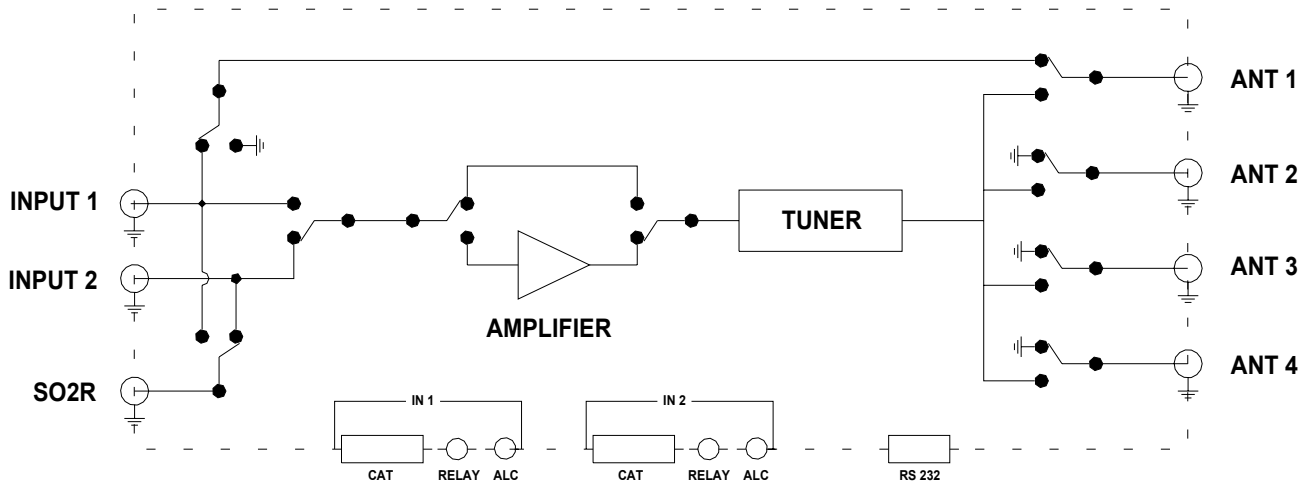

The position of the contacts, as shown in the diagram, is the situation of the linear amplifier in OFF state.

The linear amplifier can be used in the following ways:

- 1) OFF Only two direct connections are actuated:
 between INPUT 1 and ANT 1
 between INPUT 2 and SO2R
- 2) STANDBY All the functions are activated (band change, antenna change, tuner control) but the transmission is from the transceiver only.
- 3) OPERATE All the functions are activated and the transmission is using the linear amplifier.

Note: regulation of the exciter's power is automatic through the ALC connection. With the ALC connected, the amplifier input power in OPERATE mode is reduced to the correct level to drive the amplifier. In standby, the exciter will give the output power as set by its POWER OUTPUT control. Without the connection, you have to manually regulate the exciter power to drive the amplifier correctly.

Note: for continuous duty cycle transmissions (RTTY, PSKxx, SSTV, FM, AM etc.) we recommend switching the power to "HALF" state.

4.1 SO2R (Single Operator Two Radio)

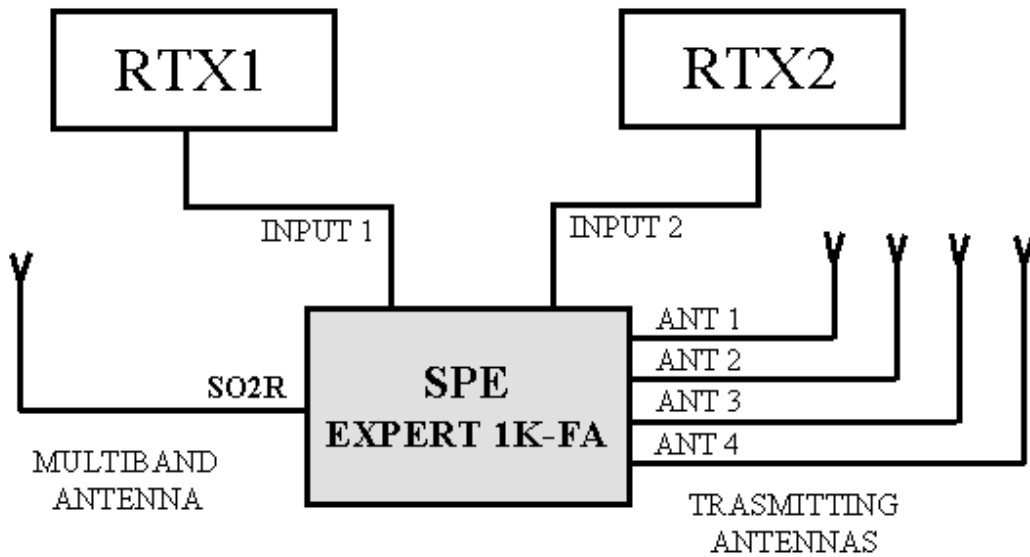

This kind of operation is used during a contest in order to acquire, as more quickly as possible, a new multiplier.

The following connections are needed (see the diagram):

1. INPUT 1 connected to the first transceiver (RTX1).
2. INPUT 2 connected to the second transceiver (RTX2).
3. ANT 1/2/3/4 connected to the available antennas set.
4. SO2R connected to a multi-band antenna.

The operating mode could be the following:

If you are operating using RTX1 on a given band (e.g 20 m), the correct antenna (ANT 1/2/3/4) is automatically selected while RTX2 is connected to the multi-band antenna in RX mode on another band.

If, when operating on 20 m, a multiplier of interest is heard on RTX2 (e.g 40 m), the only action needed is to push the PTT2 in order to RTX2 to the 40 m antenna, while RTX1 will be switched to the multiband antenna in order to receive the 20 m band.

Note: the isolation between the transmitting antennas and the receiving antenna must be very high and, therefore, very well planned. Locating the antennas at some distance from each other, and using appropriate band-pass filters will help to achieve this.

SPE cannot be responsible for any damage caused to equipment by using this mode of operating.

5. EXTERNAL GROUND CONNECTION

 **WARNING!** Before connecting an external ground as described below, check with a qualified electrician that your national wiring codes permit such a connection.

To reduce TVI, BCI and other RF problems it is sometimes helpful to connect the amplifier to a good RF ground.

The inductance of such a connection has to be low, so the connection to ground should be as short and direct as possible. Large-section copper conductors should be used for this purpose. Terminating the earth connection with a small metal plate is suggested.

The best solution is to have a ground stake, driven into the ground, and used only for the radio station.

Often good results can be achieved using correct earthing clamps, connected to the mains water supply pipe (attention, most water pipes are now in plastic).

DO NOT use central heating pipework.

AVOID the electric circuit ground of the building (to be used for the 50/60 Hz safety only).

 **WARNING! DO NOT** connect to gas pipes because there is danger of explosion !!

6. ANTENNA

Because this is a high-power amplifier, it is necessary to use correctly-rated antennas and feedline cables.

Take special care with antennas with traps, because trap warming can occur during periods of high-power transmission and a high SWR can result.

Always use antennas with SWR less than 1,6:1, even if the tuner is able to overcome some mismatches greater than 3:1.

With the tuner the PA is matched, but with a high VSWR, the cable is mismatched and there can be consequent loss of power, heating and high voltages present.

Always operate with the best possible matching because, despite the amplifier's protection against high SWR, continuous use into a mismatched load (a bit lower than the protection threshold) may lead to damage.

It is suggested that suitable static protection be given to antenna feeder cables.

7. POWER SUPPLY

The power supply unit of the SPE Expert 1K-FA has two blocks with two separate power transformers.

The first block has regulated and protected voltages, and powers all the electronic circuits for command and control.

The second block powers only the PA. It has a toroidal transformer with a low magnetic field to avoid disturbances to nearby equipment. The output voltages are 44 Vdc (on FULL-power mode) and 30 Vdc (on HALF-power mode), regulated with SCRs that also provide 'soft start' on switch-on.

This design was adopted as it provides maximum efficiency and therefore less heat to dissipate.

7.1 Mains cable termination

Your dealer will ensure that a mains plug appropriate for the country of use is fitted.

If the amplifier is used in a country other than that of the original purchase, refer to your dealer for assistance.

The default mains voltage supply of the amplifier is 230 Vac (210-250 Vac).

It may be set to 215, 200, 115 and 100 Vac also.

To change the operating voltage see below:

⚠ WARNING! - REMOVE THE MAINS CORD FROM THE WALL SOCKET AND WAIT AT LEAST 2 MINUTES FOR CAPACITORS TO DISCHARGE.

Only then, remove the bottom cover, the plastic protection and connect following the diagrams below:

Single-phase 3-wire line (210-250 VAC)

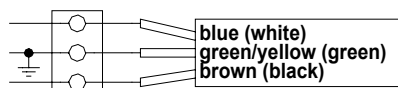

The green / yellow wire from AC power cable must be connected to the ground wire.
The blue and brown wires from the AC power cable can be connected to either terminal.

Single-phase 2-wire line (105-125 VAC)

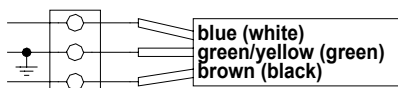

The green / yellow wire from AC power cable must be connected to the ground wire.
The blue wire from AC power cable must be connected to the hot (live) wire.
The brown wire from AC power cable must be connected to the return wire.

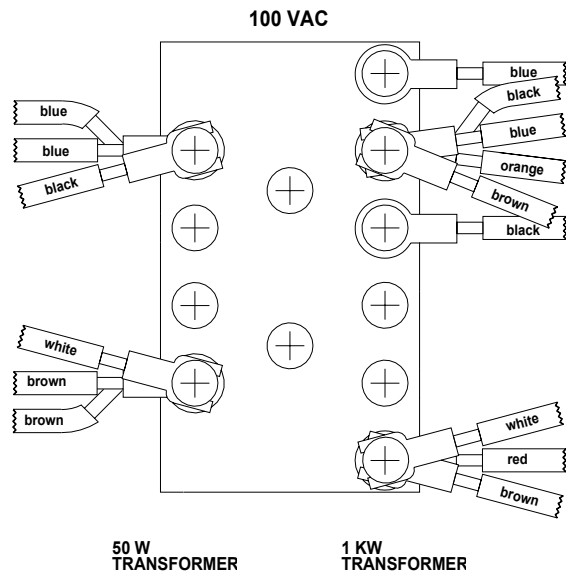
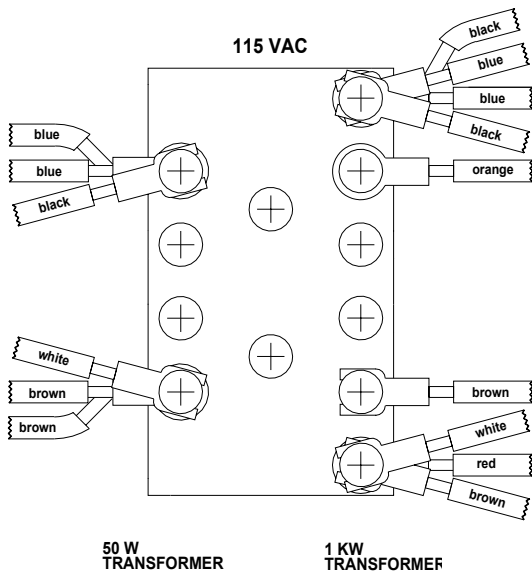
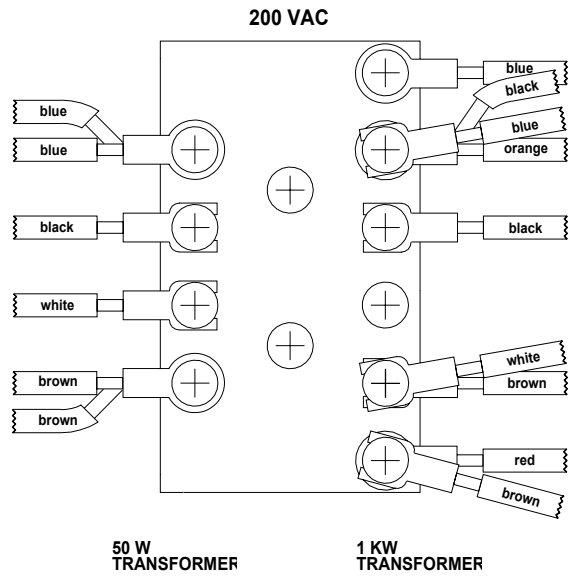
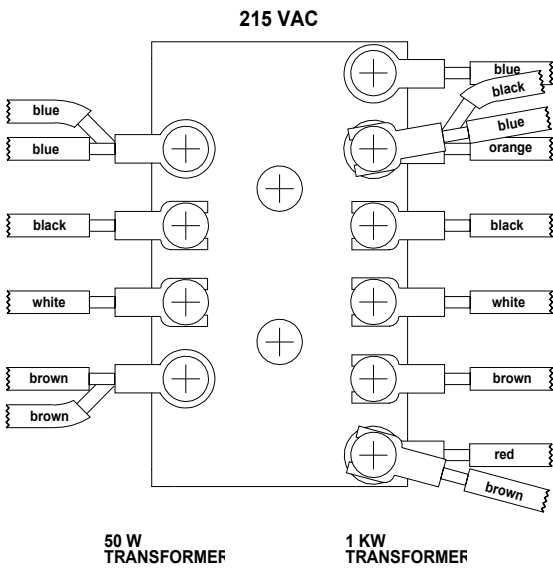
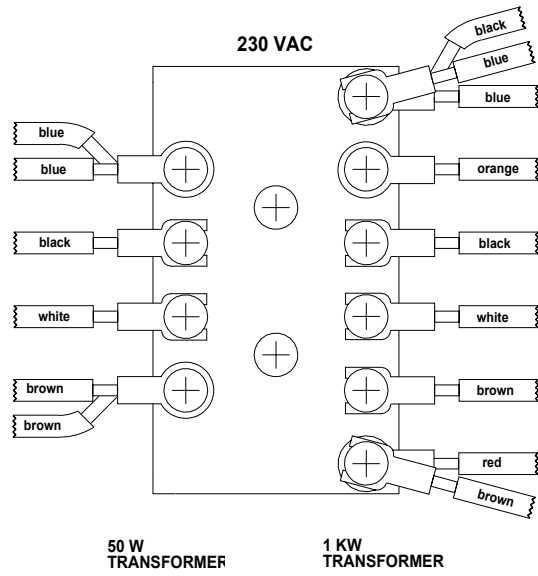

After checking your wiring, re-install the plastic protection, the bottom cover and make sure that, when using 115 and 100 Vac, in "Fuse 1" there is a 1A fuse and in "Fuse 2" there is a 20A fuse (included in the packaging).
Mark the voltage change on the back panel.

8. TUNER

The amplifier has an automatic tuner that handles load mismatches up to 3:1 VSWR (2.5:1 for 6 m).

The circuit used is a PI – L network with excellent harmonic suppression.

The amplifier contains a look-up table with all the permitted bands.

For tuner management, antenna data and other working data are stored.

Every band has a sub-band set, and for each of those, data related to the antenna and auto-ATU tuning is stored.

The CAT and the frequency counter detect the operating frequency and the correct sub-band. Thanks to the stored data, the tuner and the antenna are automatically set correctly.

For every input there is a different table. If two exciters are connected at the same time, each exciter can have different configurations.

It is possible to use the two different tables when the amplifier operates at two different locations. In fact it is possible to use the INPUT 1 at one and INPUT 2 on the other. In this way repeated reprogrammings are not needed

Furthermore, table driven management is useful to inhibit operation of the amplifier, for instance when an antenna for a particular band is not available.

All auto-tuner functions remain, on standby, whilst using the transceiver only.

Setting of the match data to write to the tables is performed automatically by pressing the [TUNE] key. The system will then find the correct match for minimum SWR.

To achieve a better match than that achieved with the automatic tune routine (most unlikely) it is possible to set the tuning manually by using the keys [◀C], [C▶], [◀L], [L▶].

When manual tuning has been performed, it is possible to read the tuning value, the working frequency and the associated sub-band on the appropriate screen page.

Both the types of tuning are always effected in "STANDBY" state.

Note: the tuner, like all analog circuits, introduces a loss (0,8 dB max.) that may vary with tuning conditions. The power meter of the amplifier does not show this loss as the power is measured at the tuner input where the load resistance is always constant (50 ohm).

Note: ATTENTION: When the amplifier is either in "STANDBY" or "OPERATE" mode, always disable the automatic tuner in your transceiver.

Note: ATTENTION: As two different tables are used for INPUT1 and INPUT2, it is necessary to make separate matching, for the same antenna, depending on the used input. Ignoring this caution could make the amplifier work for a long period with a high SWR and this practice could seriously damage the amplifier even if the protection level is not exceeded.

9. PROTECTIONS / ALARMS

The SPE EXPERT 1K-FA has a sophisticated protection system that constantly controls the amplifier's most important parameters.

These parameters are:

Temperature of the heatsink; max. / min. voltage on the PA; max. PA current; SWR; reflected power; max voltage RF on the tuner; input power; power combiner balance.

Note: unlike all the other linear amplifiers that measure only the reflected power of the antenna, to guarantee a greater protection of the PA, the SPE amplifier measures also the power of harmonics reflected by the band-pass filter.

Note: to guarantee the maximum efficiency with the same output power, the PA has three MRF150 push-pull amplifiers connected through a combiner.

Note: temperature measurement is used also to control fan speed. The thresholds where the speed changes may be changed from NORMAL (default) or CONTEST (See the "Programming" chapter of this manual).

The protection system is effected in two different ways:

- 1) Through hardware circuits to guarantee minimum intervention time.
- 2) Through software, with one of the two CPU's, to guarantee the maximum precision.

The two results are always compared, every difference produces a protection trip and consequent alarm.

There are three types of protections/alarms:

- | | |
|------------|---|
| a) SIMPLE | This is the most common case. An acoustic warning beep sounds, but no operator intervention is required, as the control system automatically restores the correct operating conditions. |
| b) SERIOUS | When automatic system recovery is not possible (e.g. the temperature climbs over the limits due to obstruction of the fans, SWR is too high, etc.). In this case the amplifier switches into standby state and the alarm is stored. Normally transmission can continue with the exciter only. |
| c) FATAL | If the amplifier is in the b) situation but the CPU is faulty or it isn't able to operate, the amplifier is turned OFF with no other warning. To restart the amplifier, the main switch in the rear panel has to be set first to [O], and then to the [I] position |

Note: it is possible to read the alarms history in the standby mode using the [DISPLAY] key. To reset the alarm file log press the [TUNE] and [OPERATE] keys together. For further details, please consult the next paragraphs.

Note: if the acoustic alarm is very frequent during transmission, the possible causes should be investigated.

Note: before the temperature limits are reached, the output power will change from FULL to HALF automatically, so that transmission with the amplifier may continue with reduced power.

In SSB the use of the compressor is recommended only when necessary; this strongly reduces the temperature increase.

If the temperature is allowed to rise further, then a "SERIOUS" alarm will eventually be activated.

Note: during a SERIOUS alarm, there is an acoustic alarm for 10 sec. Pressing the [DISPLAY] key, the system changes to 'STANDBY' state immediately.

Note: ATTENTION :when a "FATAL" alarm occurs immediately contact your reseller.

10. PROGRAMMING

The three [SET], [◀▲] and [▼▶] keys, underlined with an orange line, permit programming the amplifier and they can be used in the following way:

[SET] Use it to open the menu page, to validate the choices and to exit from the menu page.

[◀▲], [▼▶] Use these to select the options.

A green led illuminates during the programming process.

To program the system is very easy. You will find your programming choices confirmed by the items shown at the lower part of the display.

Note: programming is only possible in 'STANDBY' mode.

Note: programming changes take effect only after exiting from the menu page (the green led turns off).

10.1 Ways to operate

Pressing the [SET] key opens the menu page. On the display there are the following options:

```

----- SETUP OPTIONS vs. IN 1 -----
ANTENNA          CONTEST Off          QUIT
CAT              BEEP      On
MANUAL TUNE      START      Standby
BACKLIGHT        TEMP.     °C

----- SET ANTENNAS vs. BANDS -----
[◀▲] [▼▶]:SELECT          [SET]:CONFIRM
    
```

a) ANTENNA An appropriate antenna may be assigned to each band selecting the (ANT 1, ANT 2, ANT 3, ANT 4) connector.

If you don't have an antenna for a particular band, input "NO".

```

----- SET ANTENNA vs. IN 1 -----
160 m: 1 NO | 20 m: 3 2 | 10 m: 3 2
80 m: 1 2 | 17 m: 4 2 | 6 m: NO NO
40 m: 1 2 | 15 m: 3 2 |
30 m: 2 NO | 12 m: 4 2 |
                                     SAVE

--- SET 1st ANTENNA FOR 160 m BAND ---
[◀▲] [▼▶]:SELECT          [SET]:CHANGE
    
```

This setup allows to preset up to two antennas for the same band. Both antennas can be switched using the [ANT] key while working either in "OPERATE" or in "STANDBY" mode.

- b) CAT Allows you to program the amplifier to accept control commands from specific transceiver types.
 You may need to refer to your transceiver user manual to ensure that it is correctly programmed to handle such a link.

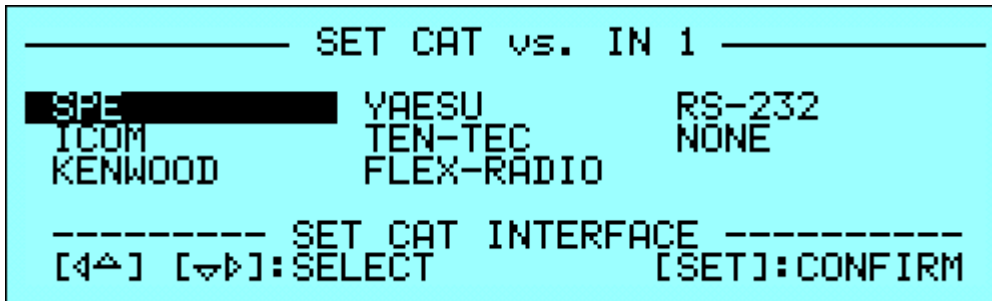

Select the brand or function:

- SPE No further programming is necessary, all is already programmed for the SPE transceivers.
- ICOM You need to choose between “CI-V”, or “Band Control Voltage “ if you use the analog connection (read the “CAT CONNECTIONS” chapter of this manual).
 If you choose “CI-V”, you also need to choose the baud rate which is usually 9600.
- KENWOOD You have to choose the baud rate (almost always 9600).
- YAESU If you use the CAT connection (read the “CAT CONNECTIONS” chapter of this manual), select the model of the transceiver and then select the baud rate (almost always 4800). If the model isn't in the list, select “Band Data” (read the “CAT CONNECTIONS” chapter of this manual).
- TEN-TEC Make the CAT connection (read the “CAT CONNECTIONS” chapter of this manual) and follow the menu instructions.
- FLEX-RADIO Make the CAT connection (read the “CAT CONNECTIONS” chapter of this manual) and follow the menu instructions.
- ELECFRAFT Make the CAT connection (read the “CAT CONNECTIONS” chapter of this manual) and follow the same indications as for KENWOOD.
- RS232 With a proper protocol it is possible to use this port not only as a remote control but also as a CAT port (useful to link the linear with any customer application).
 Download the protocol specification from the website www.linear-amplifier.com
- NONE Program when there isn't a link with the Transceiver.
 The amplifier frequency counter will then be used .

Note: if using the CAT, check that the baud rate of your transceiver is set to the same value as you program to the amplifier.

c) **MANUAL TUNE** Allows you to tune the amplifier manually. However, achieving a better setting than that obtained by automatic tuning is very unlikely.

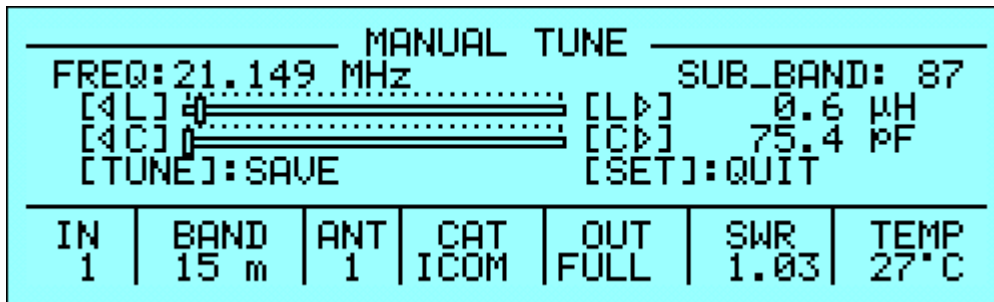

Set your exciter to transmit a continuous RTTY or CW signal. Press the [◀ L], [L ▶], [◀ C], [C ▶] keys until you obtain the minimum SWR.

The operating frequency and the sub-band are also shown on the display.

Note: the tuning process has to be repeated for every entry (INPUT1, INPUT 2).

d) **BACKLIGHT** Regulates the backlight of the display.

Note: display contrast has to be set manually. Remove the upper cover and adjust through the hole at the upper right of the CPU card. Adjust only if it is necessary, and use an insulated screwdriver with care.

e) **CONTEST** Permits programming fan thresholds for normal operation (Normal) and heavy-use (Contest).

off : Normal 40 °C, 70 °C, 83 °C (104 °F, 158 °F, 181 °F).

on : Contest 60 °C, 75 °C (140 °F, 167 °F).

f) **BEEP**

on : All acoustic warnings alarms operate and a beep confirms a keystroke.

off: When you press a key there is no beep feedback, but for all warning conditions and alarms, the acoustic warnings are still functional.

g) **START**

standby: STANDBY mode at startup.

operate: OPERATE mode at startup.

h) **TEMP**

°C: Display temperature readout expressed in Celsius degrees.

°F: Display temperature readout expressed in °Fahrenheit degrees.

To get more acquainted with the display features and to learn more about setup procedures, please refer to “18. APPENDIX 1”.

11. INITIAL OPERATION OF THE AMPLIFIER

Before turning ON the amplifier, the following preliminary operations are necessary:

- 1) Read this manual with care.
- 2) Be sure that the amplifier is correctly set for the local mains voltage supply.
- 3) Connect the amplifier to the ground circuit
- 4) Connect the antennas.
- 5) Connect the amplifier to the transceiver (read the "CONNECTIONS WITH THE TRANSCEIVER" chapter of this manual)

Operate [I] the main switch on back panel, and press the [ON] key on the front panel. Select the INPUT for the transceiver, and always carry out programming with the amplifier in STANDBY. If you change INPUT you have to repeat this programming.

Note: you may have to repeat some programming if you change antenna, transceiver, etc.

Note: ATTENTION the 'RELAY' and 'CAT' signals in some types of transceivers are only turned ON from a transceiver MENU. Refer to the user manual.

Note: ATTENTION, when the amplifier is on the 'STANDBY' and 'OPERATE' modes, always disable the transceiver auto-ATU.

11.1 Initial Programming

You must carry out the next steps in the sequence below:

a) Set Antenna.

Press [SET] and open the "ANTENNA" menu page.

Assign an appropriate antenna for the band concerned. If you don't have an antenna for a band, input "NONE".

When all the antennas are programmed, exit and go back to STANDBY.

b) Set CAT.

Press [SET] and enter the "CAT" menu page.

Select the transceiver brand and progress with programming according to the type of connection between the amplifier and the transceiver (read the "CAT CONNECTIONS" chapter of this manual).

At the end of programming, exit and go back in STANDBY.

To verify the correctness of programming, press the [CAT] key, and all the data stored will appear on the display.

To verify the correct "CAT" operation, press [SET] and select "MANUAL TUNE", While changing your transceiver VFO, you should see the amplifier frequency display follow. Then return to STANDBY.

In the same way, if "BAND CONTROL VOLTAGE" or "BAND DATA" are connected, check that the amplifier follows band changes at the transceiver.

If it does not, verify that your programming (or your link) has been done correctly.

d) Use of Automatic Tuner

To complete the programming it is necessary to match the antennas to the amplifier by operating "TUNE" (read the "TUNER" chapter of this manual). We recommend you to select each band (with available antenna) and then program the tuner for the sub-bands within which you will operate. Refer to the table in section 18 of this manual to select the appropriate sub-bands for your operating preferences.

Progress as follows:

- 1) Find the central frequency of the sub-band to tune in the table (refer to section 18 of this manual) and set the transceiver to that frequency.
- 2) Set your transceiver to transmit a continuous tone in RTTY or CW.
- 3) Press the [TUNE] key. The procedure for automatic tuning will start and then it will stop when SWR is at a minimum. Sometimes it is possible to improve tuning by pressing the [TUNE] key again.
- 4) Repeat the previous steps for all bands and sub-bands you want.
- 5) Repeat the previous steps for the eventual other antenna of the same band after having selected it using the [ANT] key.

Note: if the ALC link is not used, it is preferable to reduce the transceiver power to about 50 Watts during this operation.

Note: as a default, the table is programmed for standard 50 ohm out. If, for a band/antenna, you want to reset to default programming, proceed as follows:

- Go to the "ANTENNA" menu page and set this band/antenna to "NO", then exit from that page.
- Go to the "ANTENNA" menu page again, assign the appropriate antenna to this band, then exit from that page.

The programming will be reset for 50 ohm output.

The initial programming concludes after steps a), b), c).

To get more acquainted with the display features and to learn more about setup procedures, please refer to "18. APPENDIX 1".

11.2 Operating

You need few precautions when using the amplifier thanks its high level of automation. SPE reminds you that it is better to lose a fraction of dB in transmitted power, by slightly reducing the drive power, than to over-drive the amplifier and have a poor quality transmission.

During transmission check the parameters on the display always, because SPE has selected, designed and adjusted them with care.

SPE recommends (using the ALC link) that the transceiver should be set to its maximum drive power.

To reduce the amplifier output, if required, it is then necessary only to set the amplifier to "HALF" power state rather than changing the transceiver drive power.

Of course you may also regulate continuously the amplifier output power by changing the level of drive power from your transceiver.

If less output power than 500 Watts is desired, it is preferable, for best efficiency, to start to reduce drive from the "HALF" power state.

SETTING DRIVE LEVELS

- a) SSB: Regulate the "MIC GAIN" of the transceiver until, speaking normally into the microphone, the signal peaks on the display don't quite reach the maximum rated output power. Monitoring the transmission is a good way of checking your settings. If there is however some distortion, decrease the "mic gain" or decrease the power of the transceiver until a small reduction of the output power of the amplifier is seen.
- b) CW: In key down, you get the maximum output power automatically. Check the "PW REV". If it shows more than 120/140 Watts, decrease the power of the transceiver until that value or less is noted.
When CW mode is extensively used, a manual regulation of the exciter's output power is advisable to avoid improper ALC action if the transceiver has an excessively slow ALC regulation. Poor ALC regulation could result in overdrive, which in turn could result in damage.
- c) RTTY, DIGITAL MODES, SSTV, FM: SPE recommends you operate in 'HALF' mode because these types of transmission have a very high duty cycle. Check "PW REV", and if it shows more than 120/140 Watts, decrease the power from the transceiver. In case of very heavy use, it is advisable to work in "Contest" condition to take advantage of the greater efficiency of the fans.
- d) AM This transmission mode radiates a continuous carrier which is 25 % of its PEP value (400W PEP AM = 100W carrier power). SPE recommends you always operate in 'HALF' mode for AM. To get an output signal without distortion, proceed as follows: transmit the AM carrier only, with your transceiver "MIC GAIN" set to zero, and no modulation. Set the transceiver without exceeding 125W of carrier output from the amplifier. Then, speaking into the microphone normally, set the "MIC GAIN" of the transceiver until the peak output power, on speech peaks, as shown on the amplifier display, is no more than 500W. Note that because of the modulation characteristics of AM, the average value shown will normally

be much less. SPE suggests you monitor your transmission to check that the "MIC GAIN" setting is correct. In case of very heavy use, it is advisable to work in "Contest" condition to take advantage of the greater efficiency of the fans.

Note: if you choose to set the output power of the amplifier by varying the output power of the transceiver, the ALC connection is not required.

Note: ATTENTION, never stress the amplifier with long periods in key-down transmission, as this can stress the amplifier components.

Note: in SSB the use of the compressor is recommended only when necessary; this strongly reduces the temperature increase.

12. CAT CONNECTIONS

12.1 CAT Connector

In this diagram the rear panel CAT connector and pinouts are shown

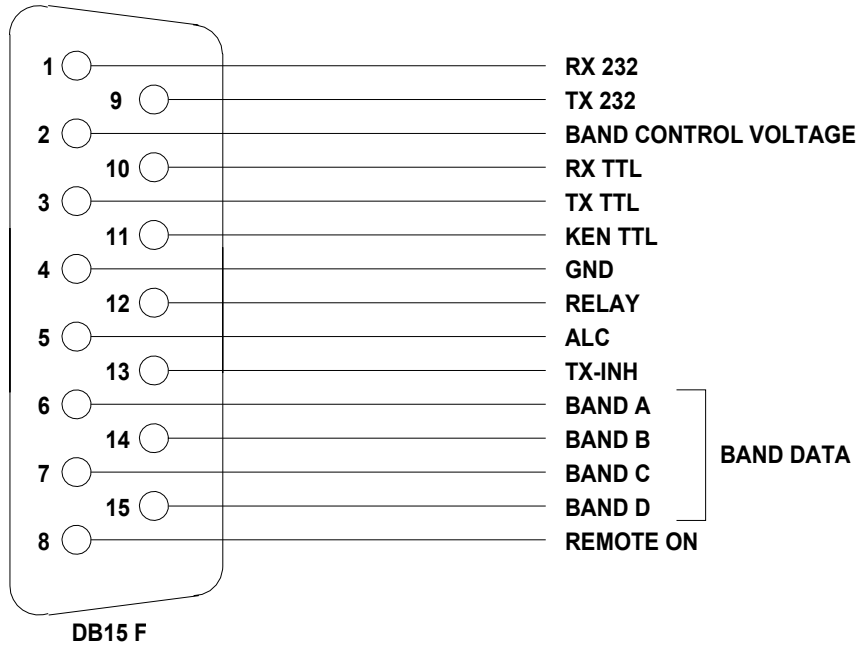

pin n°	pin name	Description
1	RX 232	Used on KENWOOD and YAESU transceivers for the link with a RS-232 connection.
9	TX 232	
2	BAND CONTROL VOLTAGE	Analog band switch on the Icom transceivers.
10	RX TTL	Used on Icom, KENWOOD and YAESU transceivers for the CAT 5V TTL connection.
3	TX TTL	
11	KEN TTL	Connect to GND if CAT 5V TTL KENWOOD connection.
4	GND	Signal ground.
12	RELAY	Connected in parallel with the RCA phono RELAY connector.
5	ALC	Connected in parallel with the RCA phono ALC connector.
13	TX - INH	Used to improve the receive / transmit switching efficiency.
6	DATA A	Bit A of Band Data (digital switch of band for YAESU).
14	DATA B	Bit B of Band Data (digital switch of band for YAESU).
7	DATA C	Bit C of Band Data (digital switch of band for YAESU).
15	DATA D	Bit D of Band Data (digital switch of band for YAESU).
8	REMOTE ON	Applying a voltage from 9 to 15 Vcc, turns the amplifier ON.

Using the above information, an appropriate cable for your transceiver(s) may be constructed, or you might wish to order a correctly made-up cable when you order your amplifier from your local dealer. The amplifier connector is included with the amplifier, and the transceiver connector (called "Radio" in the next diagram) is usually supplied with the transceiver.

For connections to the Radio connector, refer to the transceiver operating manual.

12.2 SPE

In the case of SPE transceivers, it isn't necessary to make a cable because it is supplied with the transceiver.

12.3 ICOM

CAT CI-V Interface

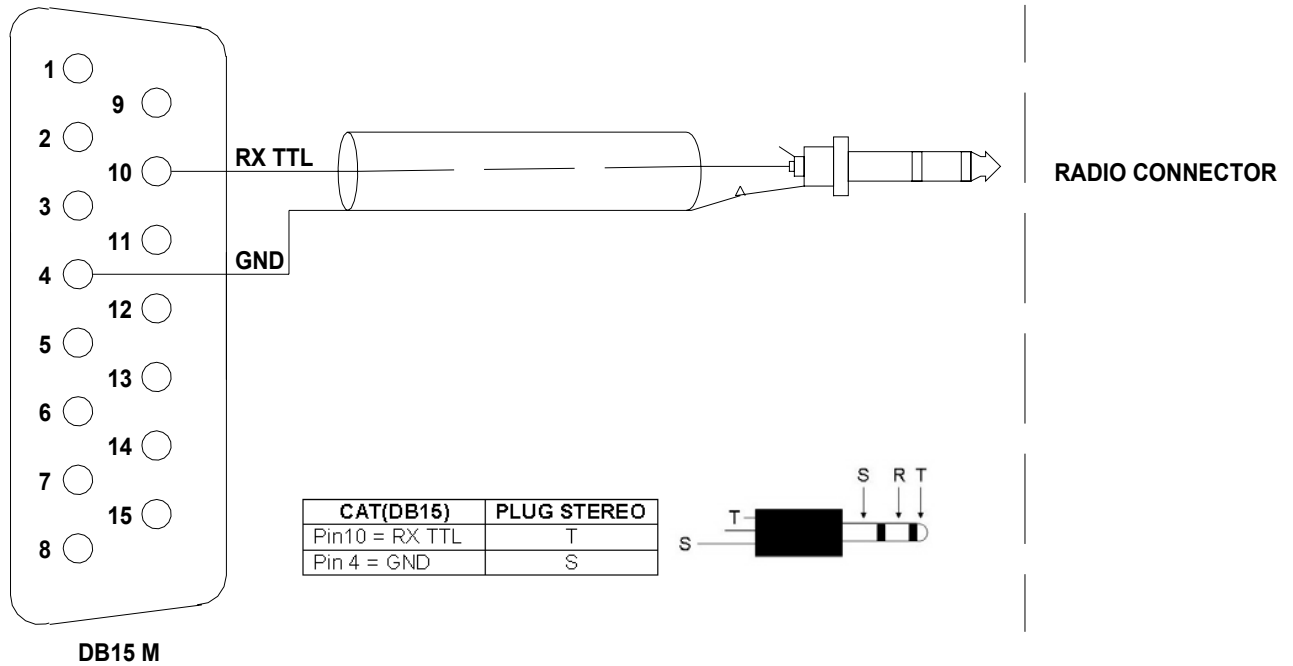

This interface is standard for all the Icom models equipped with CAT, the cable always terminates to a 3,5 mm. plug

BAND CONTROL VOLTAGE Interface

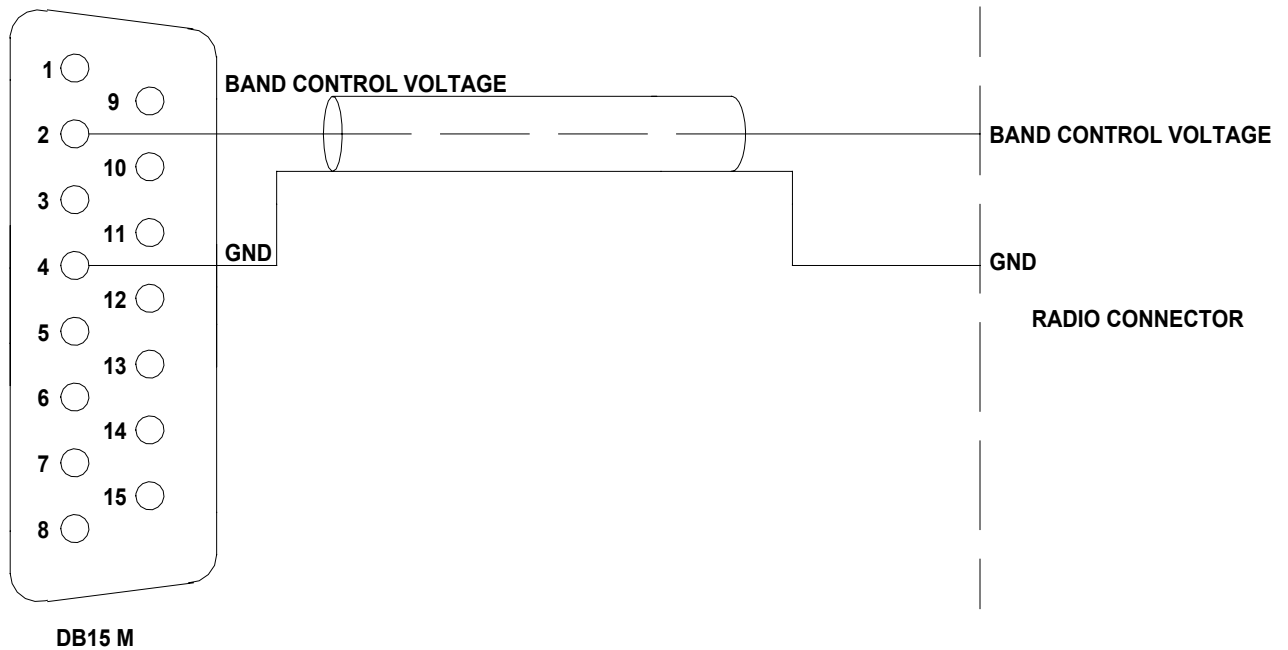

This interface is standard for all the Icom models not equipped with CAT. The change of a voltage determines the change of band.

12.4 KENWOOD

CAT RS232 Interface

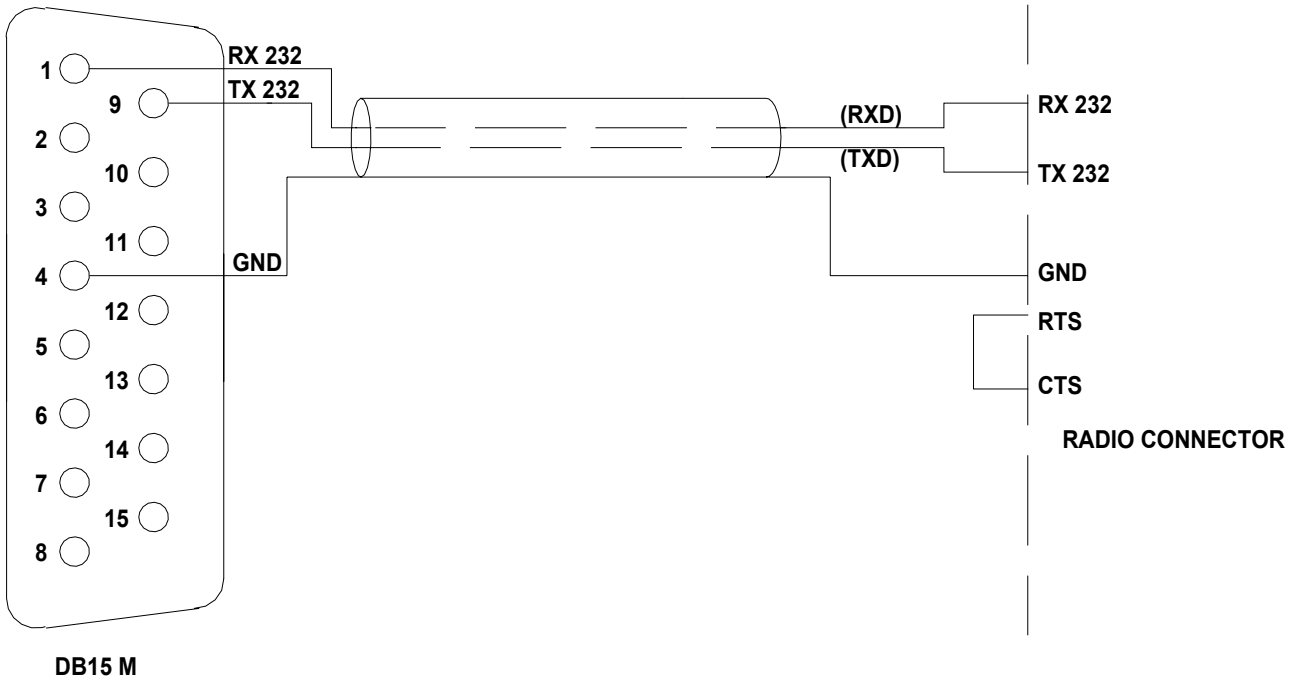

The Radio connector could be DB-9 or DB-25 male connector or female connector (read the specific manual). In the manual also verify if the RTS–CTS link is necessary.

CAT 5V TTL Interface

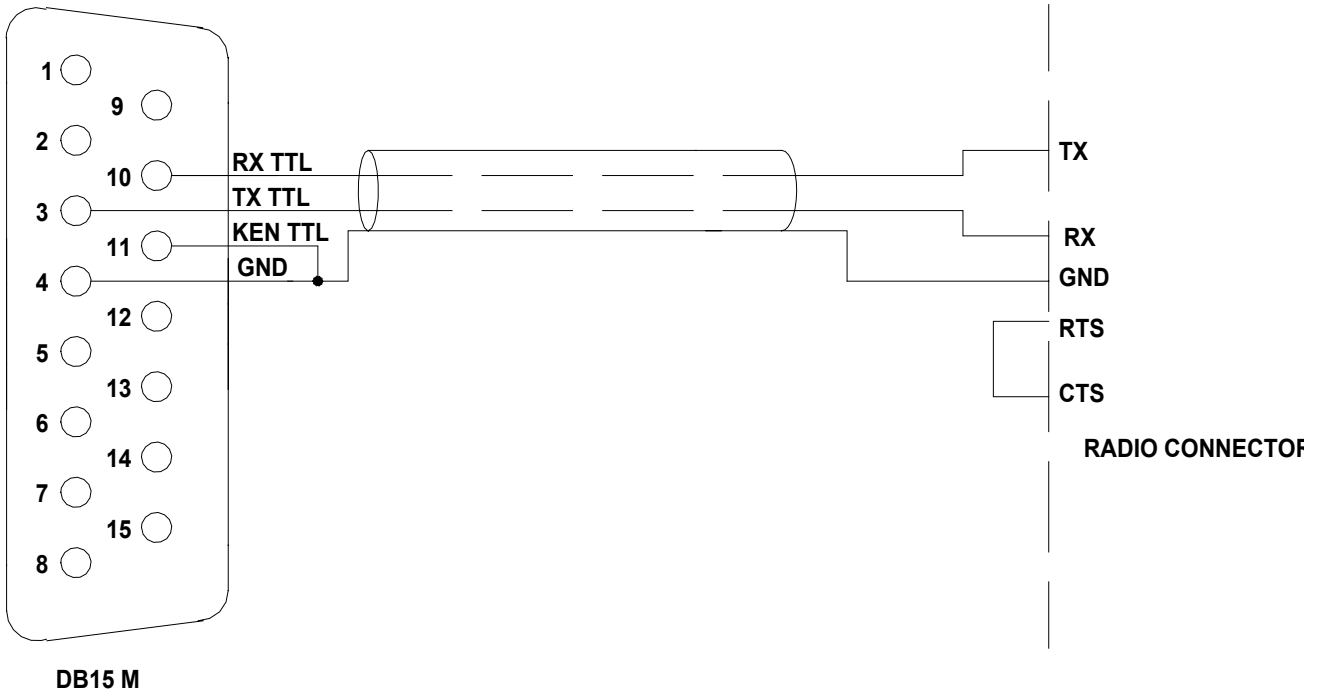

The connector is described in the specific manual. Verify if the RTS–CTS link is necessary.

12.5 YAESU

CAT RS232 Interface

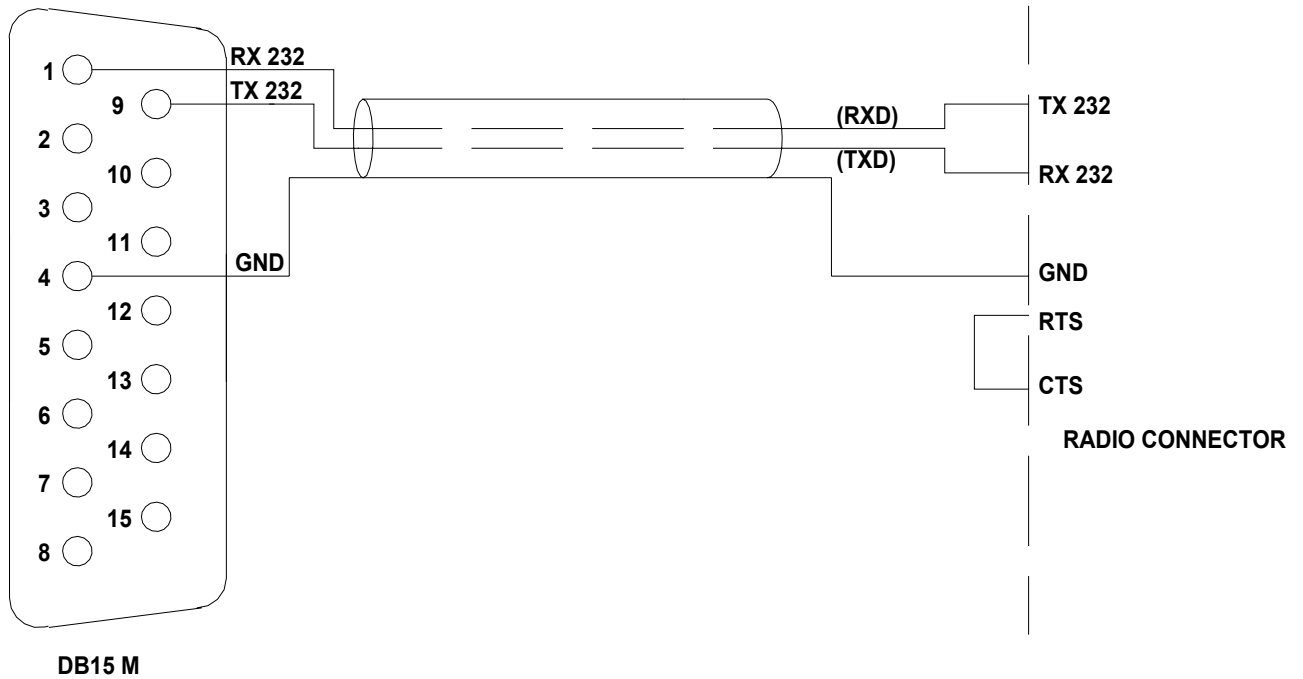

The radio connector may be a DB-9 or DB-25 male connector or female connector (read the specific manual). Verify from the manual if the RTS–CTS link is necessary.

CAT 5V TTL Interface

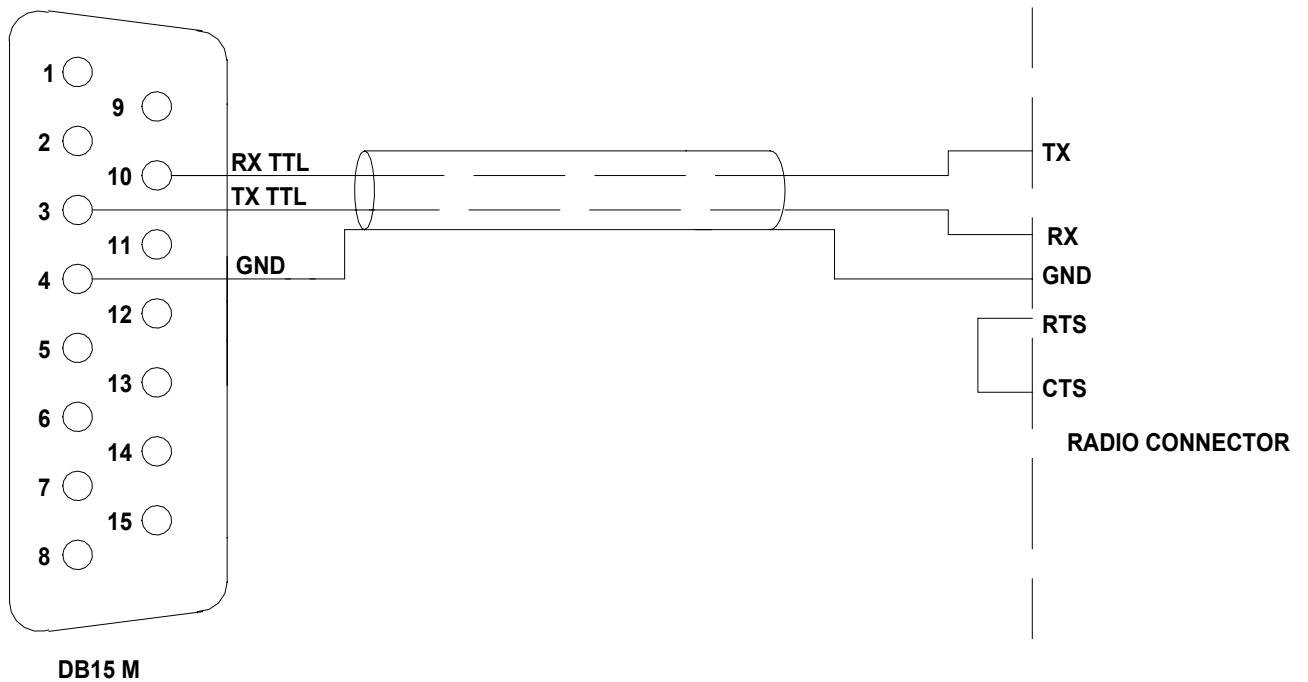

The connector is described in the manual. Verify if the RTS–CTS link is necessary.

BAND DATA Interface

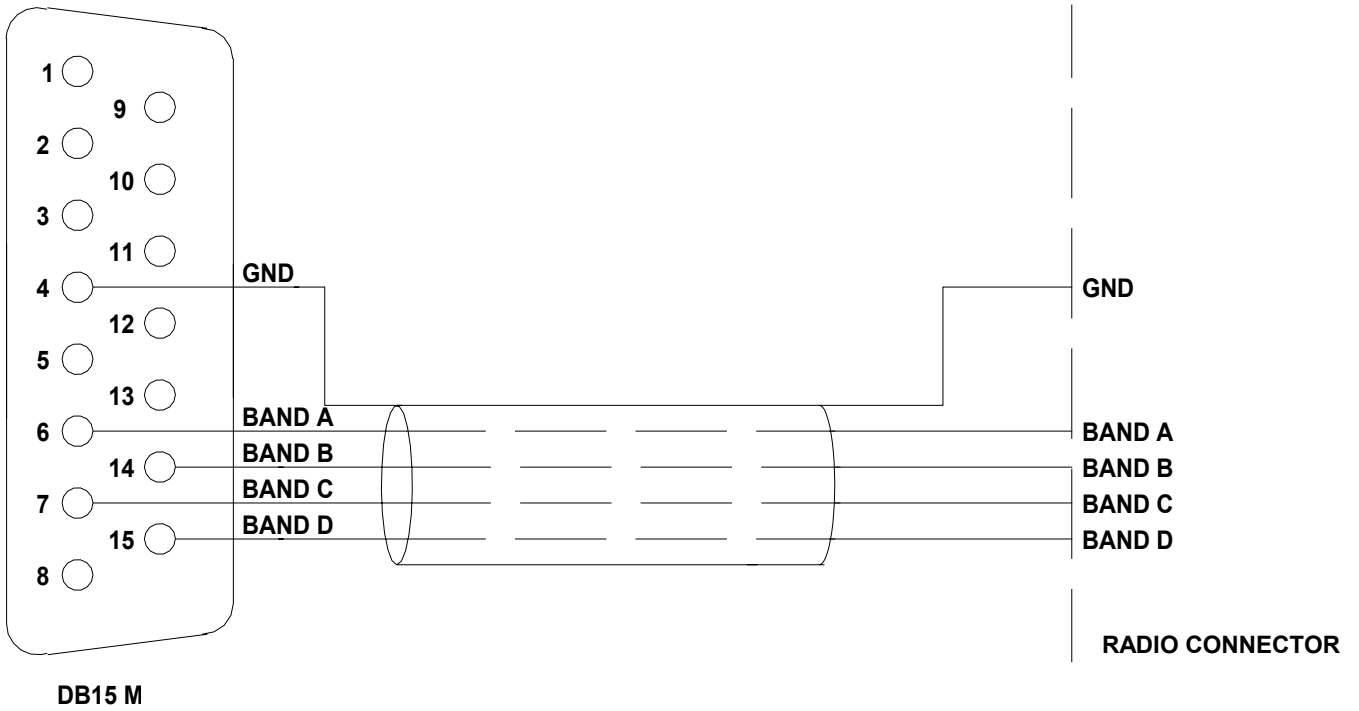

Without the CAT, the band is commanded by four digital signals (Band A, Band B, Band C, Band D). Refer to the specific manual.

12.6 TEN-TEC, FlexRadio, ELECRAFT

CAT RS232 Interface

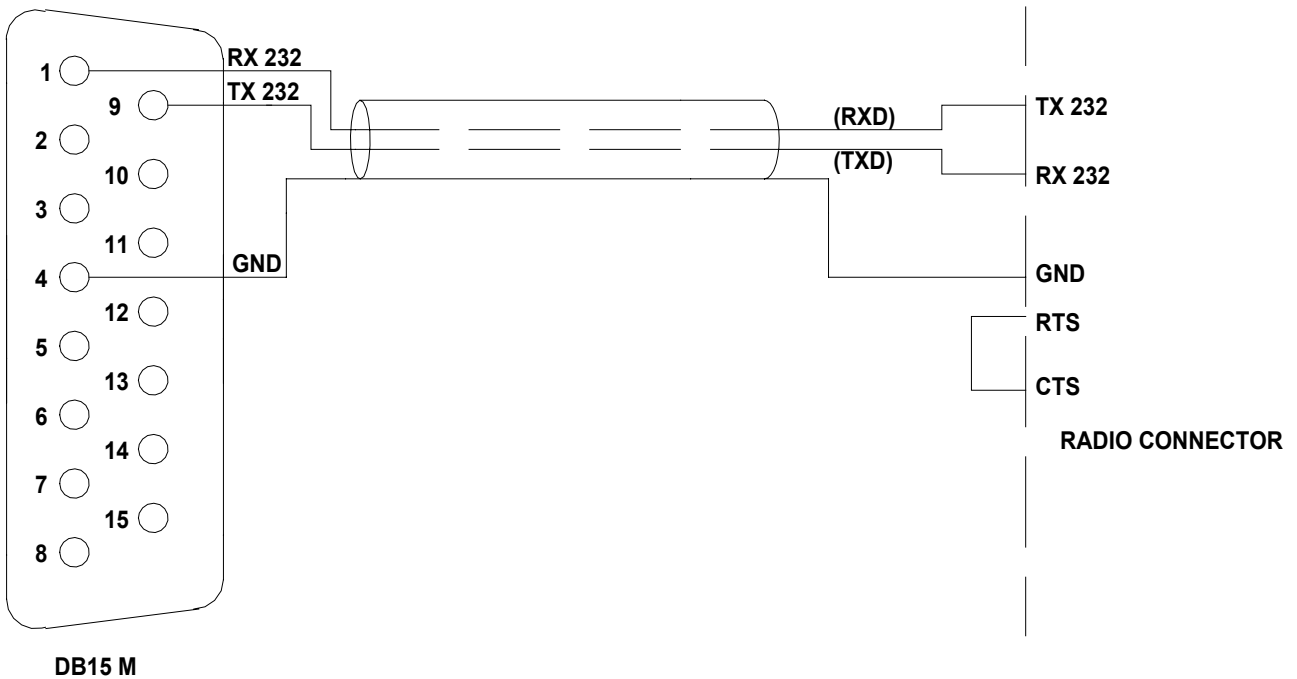

The radio connector may be a DB-9 or DB-25 male connector or female connector (read the specific manual). Verify from the manual if the RTS-CTS link is necessary.

12.7 TRANSCEIVERS OF OTHER BRANDS

A special link is not necessary as the internal amplifier frequency counter will measure the input frequency and will control the amplifier.

13 OTHER CONNECTIONS

On the 15-pin connector, in addition to the CAT signals, the ALC and RELAY signals are repeated, REMOTE ON and TX – INH are also available. If you use this connector, in some cases, separate ALC and RELAY cables may not be necessary, or it may be possible to turn the amplifier on / off by turning on / off the transceiver (REMOTE ON). The following diagram shows how to integrate all transceiver control connections to the 15-way amplifier connector.

Check the transceiver handbooks for terminating that end of the cable.

13.1 ALC, RELAY CONNECTIONS

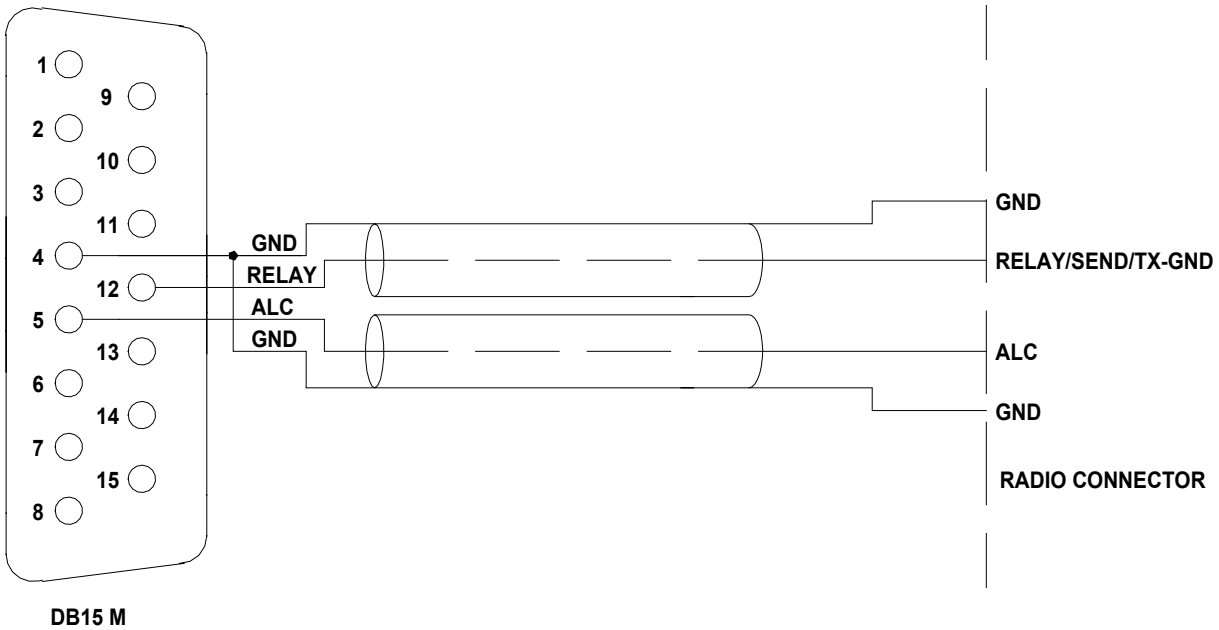

13.2 REMOTE ON LINK

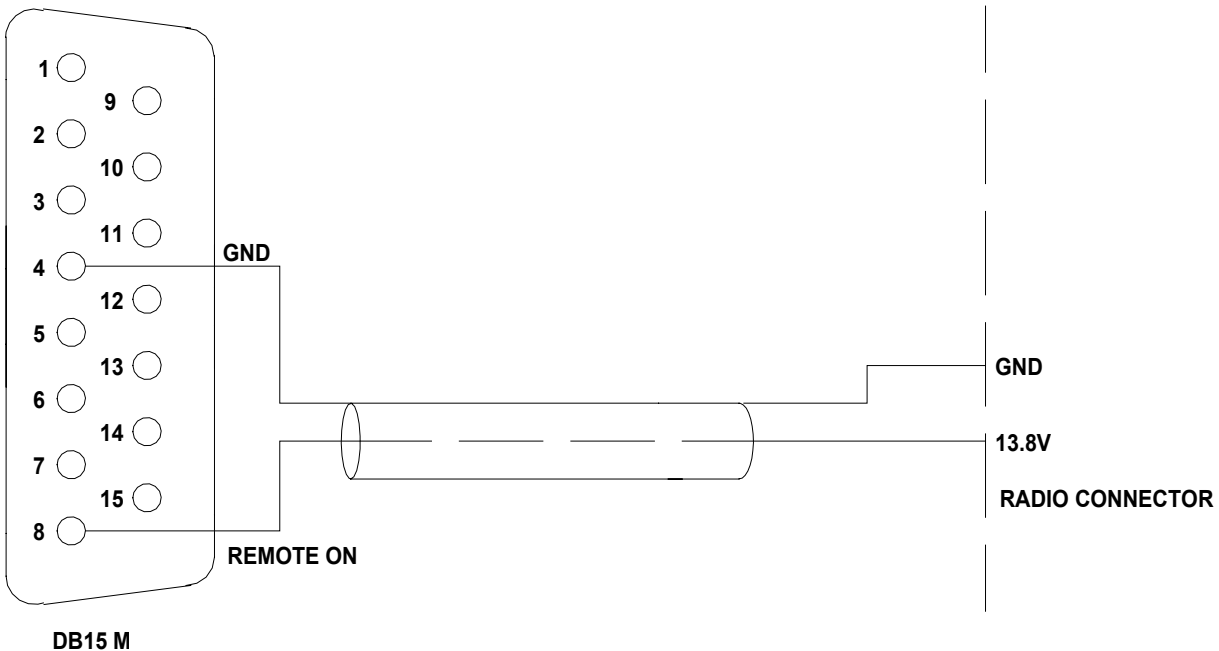

13.3 TX INH LINK

Some transceivers have a suitable input (called TX – INHIBIT, LINEAR, MUTE, etc.) that disables transmission. To improve the receive / transmit switching efficiency it is highly recommended, but not mandatory, to connect this input with the pin 13 of the linear connector (TX – INH).

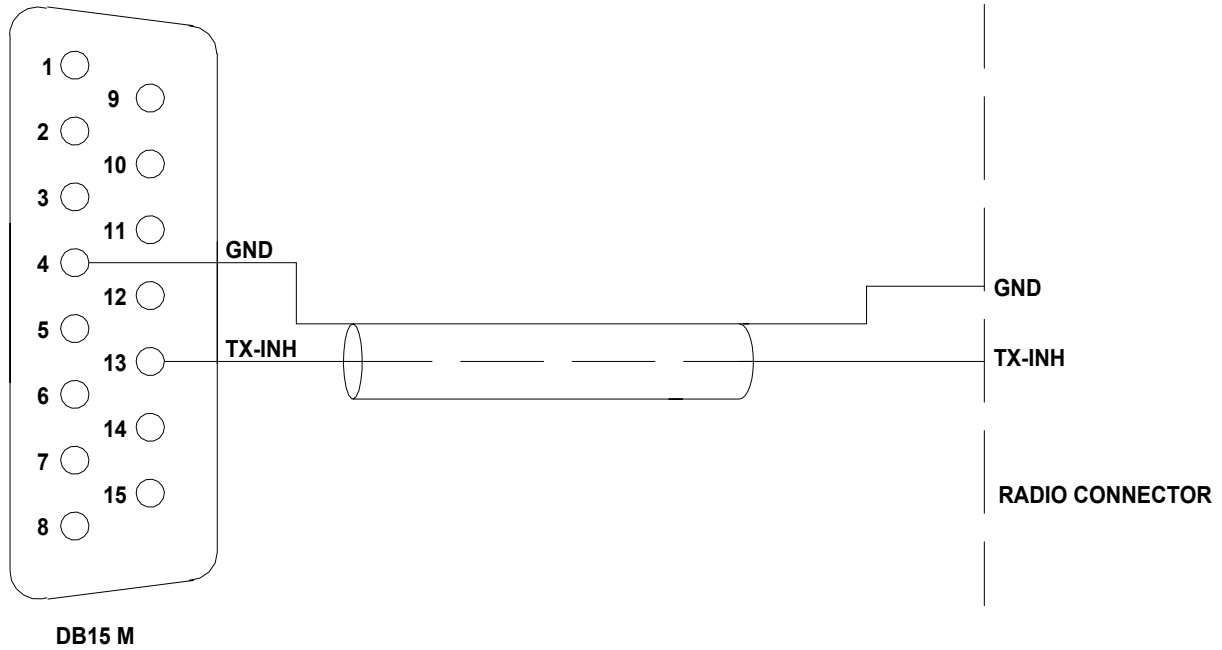

14. TRANSCEIVER CONTROLLED WITH A PC

If the transceiver is controlled with a PC using the CAT utility, the link with the amplifier can be made as described in the following paragraphs.

Note: BEWARE, SPE assures only the direct connection between the Linear and the Transceiver. The use of external control software could create malfunctions that must be resolved by the provider of such software.

14.1 ICOM CI-V INTERFACE

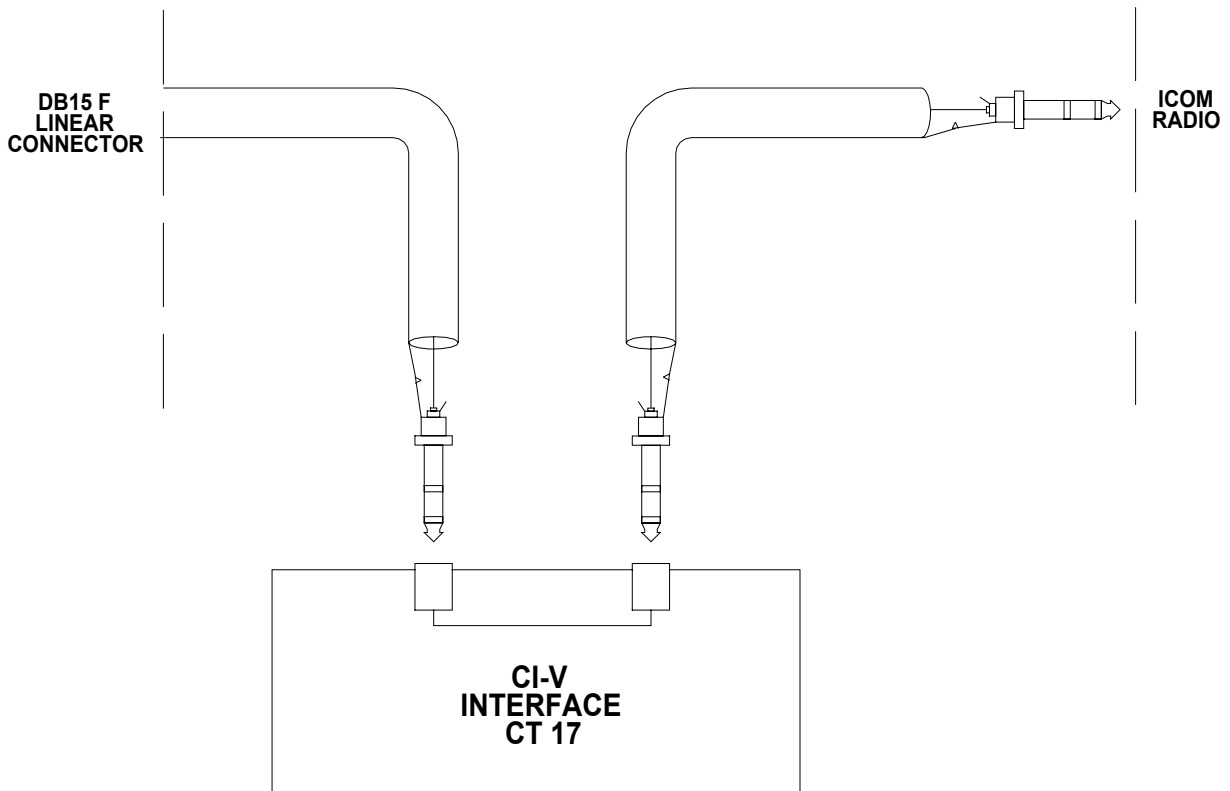

The plug from the amplifier has to be connected to a CI-V port of the CT17 or similar device. The transceiver has to be connected to another CI-V port.

14.2 RS232 INTERFACE

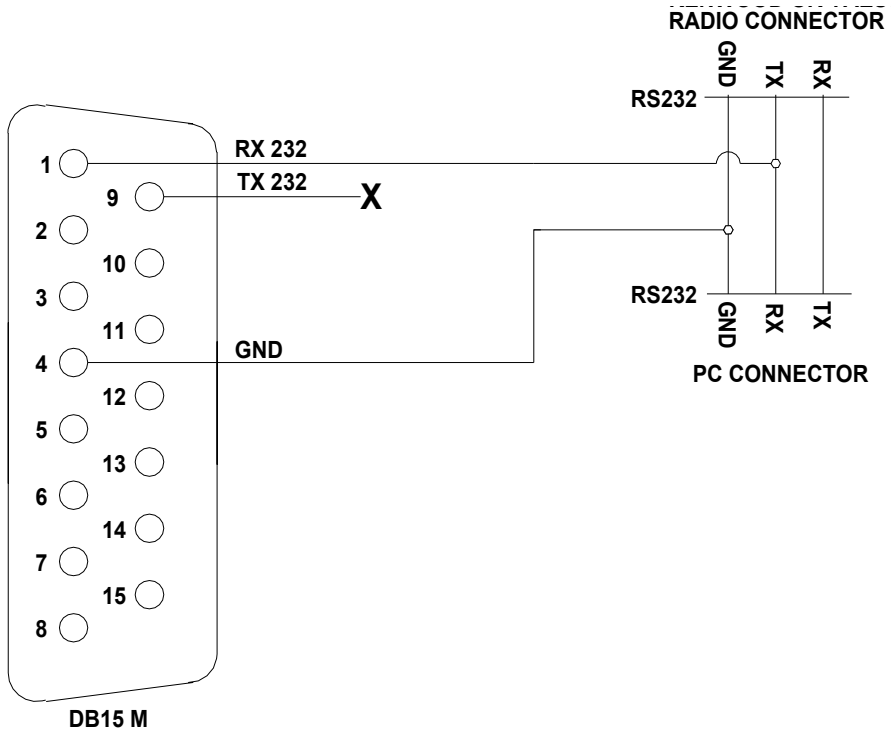

This type of link is the same for KEWOOD, YAESU, TEN-TEC, FlexRadio and ELECRAFT

On the other end of the cable it is necessary to link only GND and RX 232.

14.3 5V TTL KENWOOD INTERFACE

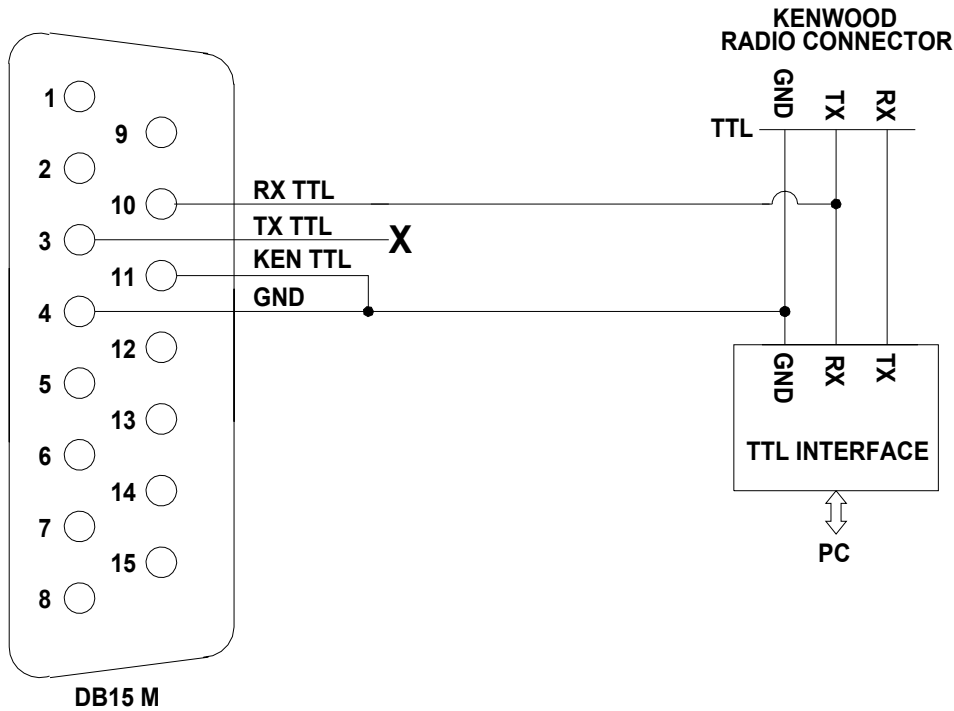

The links on the linear connector side are the same.

On the other end of the cable it is necessary to link only GND and RX TTL.

14.4 5V TTL YAESU INTERFACE

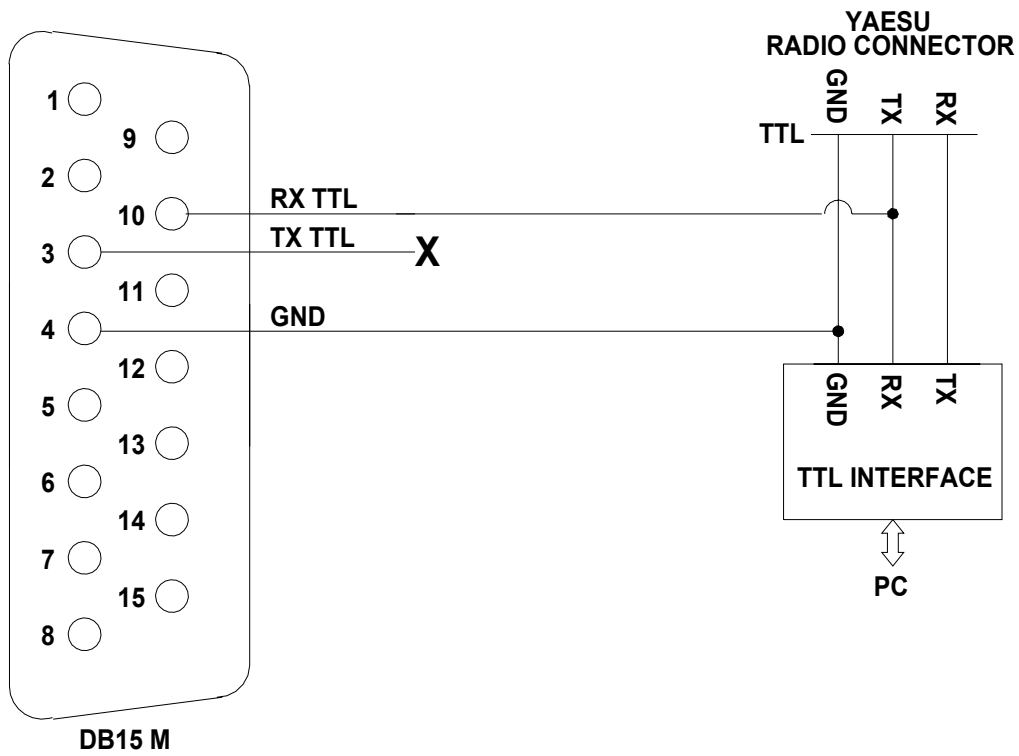

The links on the linear connector side are the same.
 On the other end of the cable it is necessary to link only GND and RX TTL.

15. USE OF THE RS-232 PORT

Through the RS232 port it is possible to interface the amplifier with a PC.

It is possible to download from the website www.linear-amplifier.com the software that permits interfacing the amplifier in a remote way, connecting the amplifier to a PC with the supplied cable.

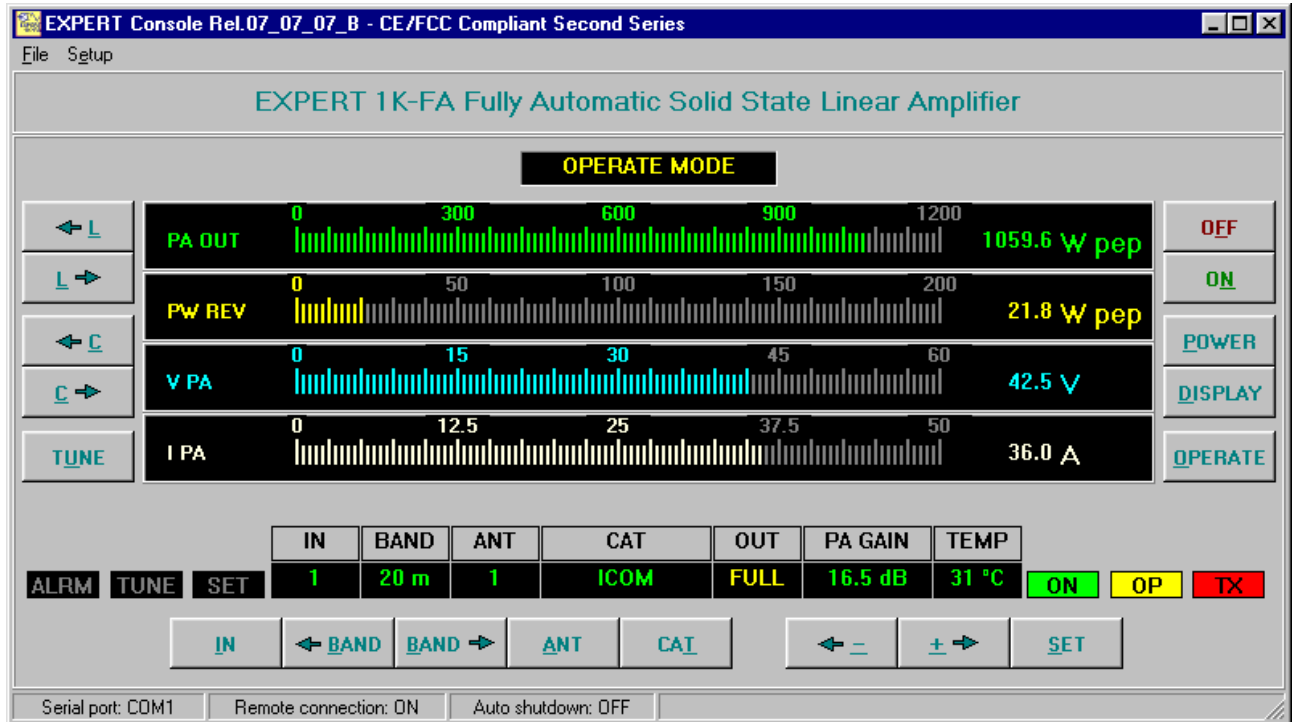

On the same website there is, for programmer use, a protocol specification that permits creation of a proper software application.

Note: SPE doesn't take any responsibility for these applications.

16. MAINTENANCE

The Expert 1K-FA linear amplifier doesn't need internal maintenance because it has a cover without ventilation holes. No tube-type EHT is used so the high voltages present in tube amplifiers, which sometimes attract dirt, are not present.

The user has only to periodically check the cleaning of the air filter on the front panel.

The frequency of such operation depends how dusty the amplifier location is and how much it is used. We recommend monthly cleaning of the filter.

To clean the filter

- a) Remove the front grid.
- b) Remove the filter and clean it with care.
- c) Reassemble the filter and the grid after having carefully cleaned the mechanical structure that includes them.

Note: check the filter if an unexpected rise of temperature is noticed.

Note: never operate without the filter, as dust could be deposited on the surface of the heatsink limiting its ability to cool.

Note: to allow the most efficient heat-dissipation, large copper parts have been used.

17. CHARACTERISTICS / SPECIFICATIONS

- **The smallest in the world**
Built-in Power supply and Automatic Antenna Tuner.
Dimension: w 28, h 14, d 32 cm. (11.02" W, 5.51" H, 12.60" D) (connectors included).
Weight: approx. 20 Kg (19 Kg typ.), 44 lbs (41.8 lbs typ.).
- **The most technologically advanced in the world**
Two CPUs are used, one of which is dedicated to the transceiver interface requirements (CAT).
Pi-L output circuit.
Over 13000 lines of software for performance that cannot be found in any other amplifier.
- **Fully Automatic**
Easy connection with all models "ICOM, YAESU, KENWOOD, TEN-TEC, FlexRadio ELECRAFT" for immediate management of the bands, tuner and antennas.
Same performance with all makes or homemade rigs.
The operator has only to move the "Frequency Tuning Knob" in the transceiver!!!
- **Wide frequency coverage**
1.8 MHz to 50 MHz including WARC bands.
- **Fully solid state**
1 KW pep SSB output; 900 W pep CW out (typ.) ; 700 W pep out. (typ.) on 50 MHz.
FULL / HALF power selected according to the operator SSB/CW power requirement, for digital modes and for linear protection (automatic).
No heating time, immediately ready!
Virtually limitless life of the amplification devices (MOSFETs).
- **Automatic Antenna Tuner built-in**
Capable of matching 3:1 SWR on HF, and 2.5:1 SWR on 6 meters.
Capable of programmable switching of 4 antennas (SO239 connectors).
Up to two antennas for the same band.
Bands, Antennas, Tuning conditions are changed in 10 msec.
Bands, Antennas and Tuning conditions are managed also in "STBY" to support the exciter only.
- **SO2R.**
- **Two inputs available.**
SO239 connectors.
- **High power gain (up to 16 dB).**
In "OPERATE" the required drive power is automatically set with an ALC connection and in "STANDBY" the exciter is then automatically reset to full power.
- **Very clean and low distortion output!**
Spurious emissions less than -50 dB (50 MHz -60 dB).
3rd order distortion (two tone test) 36 dB typ.

- **Input 50 ohm always perfectly matched**
SWR less than 1.2:1.
- **Fully protected**
Temperature, Over-Voltage, Over-Current, SWR, Reflected Power, Max RF Tuner Voltage, Over-Drive, Amp. The correct parameters are continuously monitored. The same protection is realized in two different ways:
 - Via hardware circuits (HW) to assure great speed.
 - Via the software (SW), to assure great accuracy.Thanks to the SW, transmit relay changeover is carried out with zero current at the contacts.
- **Full break-in operation (QSK)**
- **Normal / Contest operation to optimize performance**
- **Very quiet operation**
Seven quiet three-speed cooling fans:
 - 150 CFM maximum total air flow.Temperature thresholds for speed change:
 - 40 °C (104 °F), 70 °C (158 °F) and 83 °C (181 °F). (normal mode).
 - 60 °C (140 °F). and 75 °C (167 °F). (contest mode).Noise level:
 - 39 dBa at maximum blower speed.
- **Continuous use**
“FULL” mode: SSB unlimited, key down 2 minutes.
“HALF” mode: SSB unlimited, key down 5 minutes.
- **Regulated power supply, input 230 / 215 / 200 / 115 / 100 Vac**
With all input voltages the output power doesn't change.
A well designed grain-oriented, tape-wound toroidal transformer reduces magnetic fields around the amplifier .
- **The linear can be switched ON / OFF also switching ON / OFF the exciter**
- **With a large LCD display is possible to have a great deal of information**
W pep out, V pa, I pa, W pep reflected, Power gain, Temperature, SWR, Input setting, CAT setting, Band and other indications including an alarms log.
- **Easy to operate**
Powerful SW gives you a user-friendly unit.
- **RS 232 port for PC control**
SW is supplied to remote the linear front panel.
With a proper protocol it is possible to use this port not only as a remote control but also as a CAT port (useful to link the linear with any customer application).
- **Easy transportation**
A sturdy carry-bag is supplied for “QSY, FIELD DAY, DX' PEDITIONS etc.“.
- **Certifications :**
CE, FCC .

SPE guarantees all previous data on 14 MHz.
These specifications are subject to change without notice.

18. APPENDIX 1

18.1 Main Display Page (STANDBY Mode).

The **Main Display Page**, just like any other visual page handled by the system, is substantially divided into two parts:

- A **User Area** showing some information/data which vary according to the current working status.
- A **Status Bar** which is committed to displaying either the various status information or, as for the info pages visualization and setup menus, for user prompts and for short help notes (contextual helps).

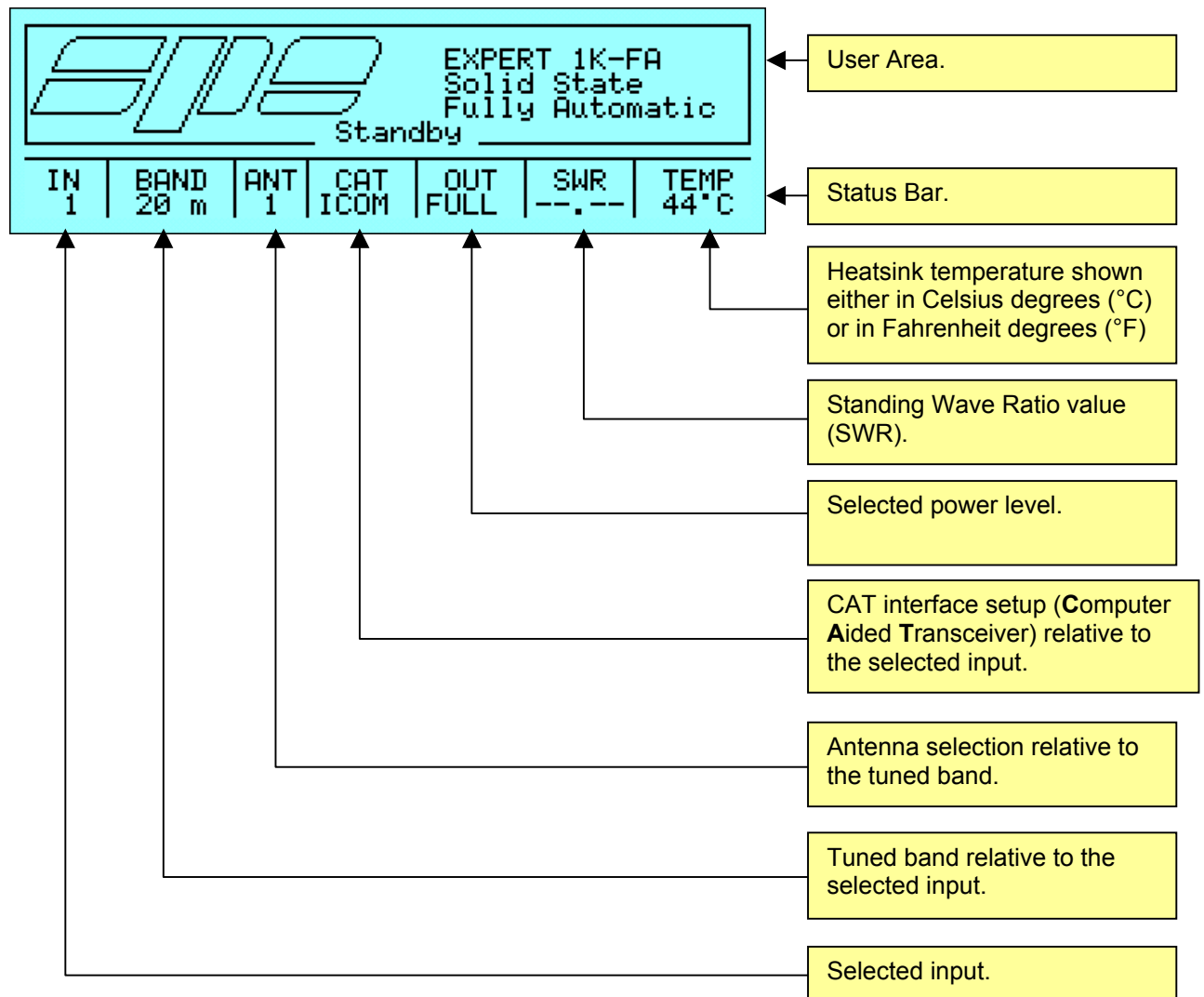

18.2 Main Display Page (TX Exciter).

When in **STANDBY** mode and, having a transceiver connected to one of the two inputs of the linear the TX is switched to, there is a context change and the **Main Display Page** showing the **STANDBY** Mode changes to another display page (**TX Exciter**) which shows the input power signal level both in graphical form (by means of a level bar) and in numerical format (W pep).

The level bar and the numerical indication have a maximum peak hold function with a programmed delay of about 1 second.

When the connected transceiver is switched back to **RX** mode the **Main Display Page** showing the **STANDBY** state is displayed again .

Reception

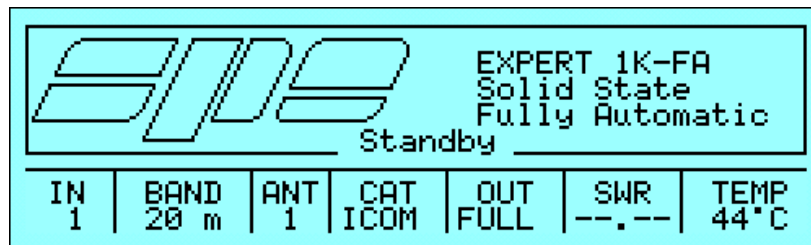

Transmission (exciter only)

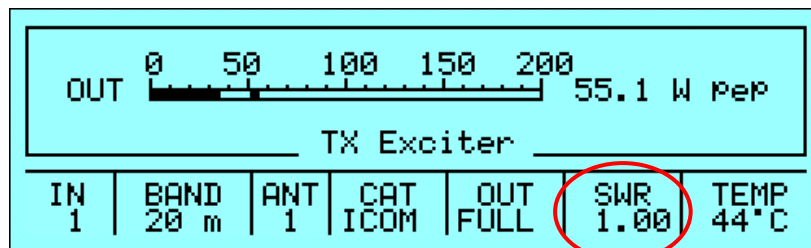

Reception

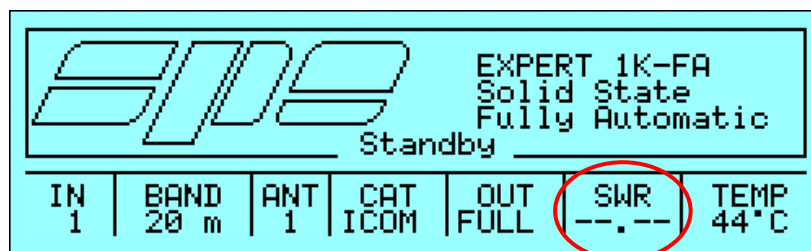

During the whole transmission period the SWR cell inside the Status Bar displays in real-time the current value of the Standing Wave Ratio; when back in reception mode the null value “---.--” is shown.

18.3 Alarm History Display Page.

If, in **STANDBY** mode the **[DISPLAY]** key is pressed, the **Alarm History Page** report is displayed; this new page shows in reverse order (the higher numerical index is the last alarm message) all the stored alarm messages since the last stack reset .

To come back to the **Main Display Page (STANDBY mode)** all it needed is to press the **[DISPLAY]** key again.

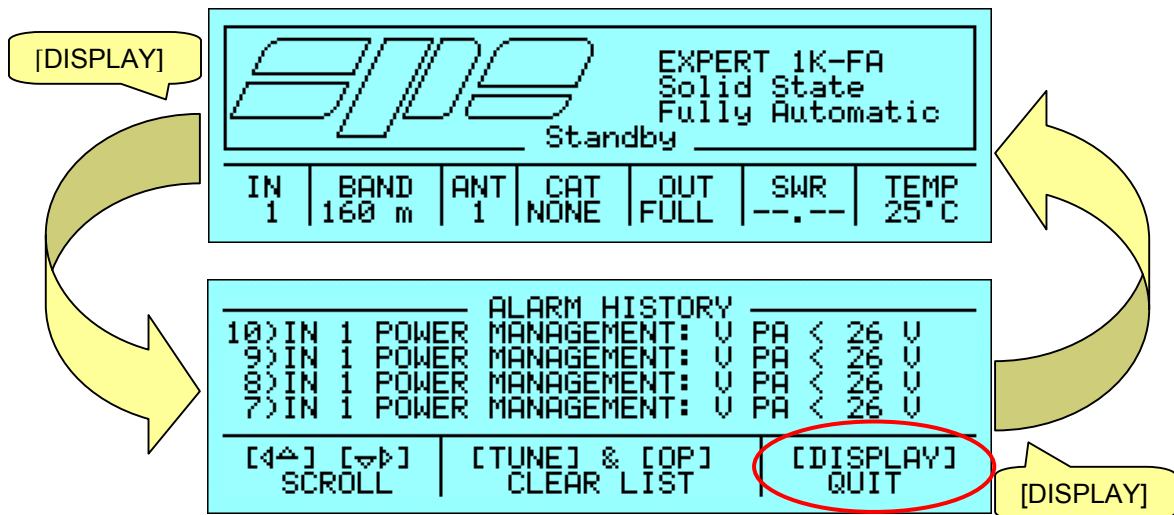

Due to the small display capability the **Alarm History Page** can show only four message lines at a time so, in order to view any other message “out of sight”, the arrow keys (**[◀▲]** **[▼▶]**) must be used to obtain the text scroll.

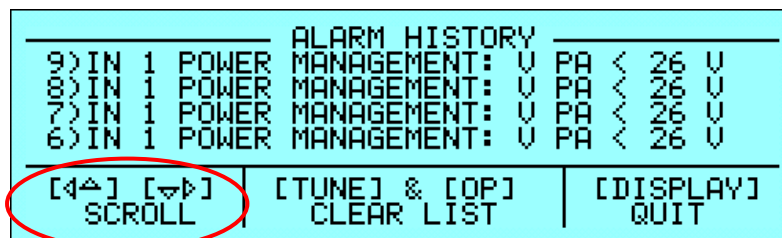

[▼▶]: one line down
[◀▲]: one line up

To empty the whole alarm stack the **[TUNE]** and **[OPERATE]** keys must be pressed and kept down till the following display page appears:

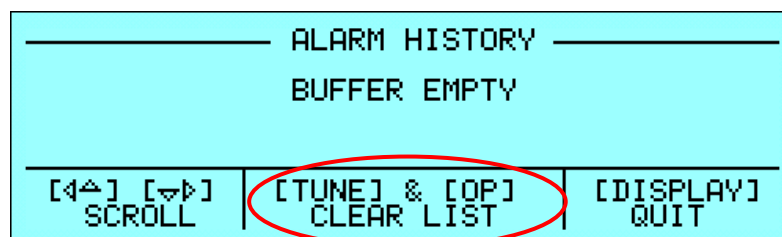

18.4 Setup Options Menu.

The **Setup Options Menu** can be accessed using the **[SET]** key while standing in the **Main Display Page**:

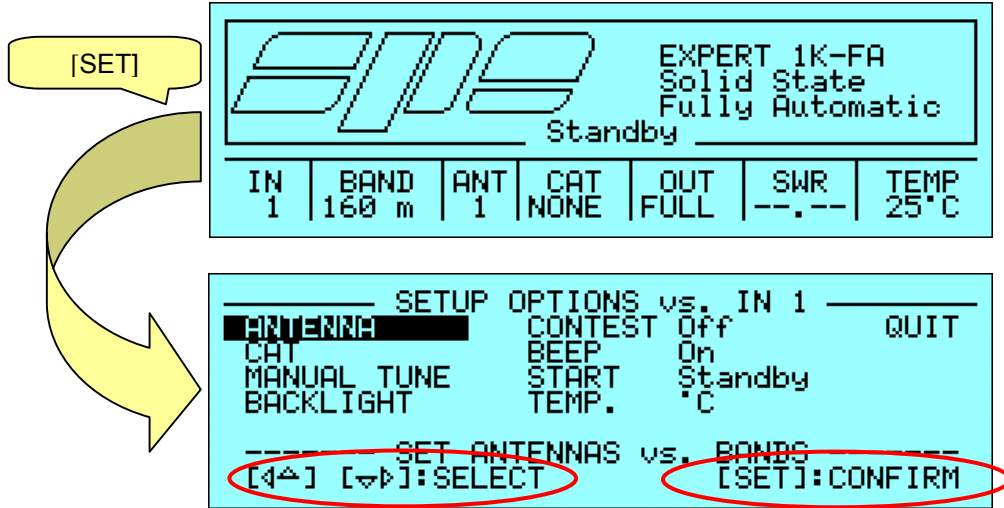

A menu composed of various items which can be selected will be displayed, one item at a time, using the arrow keys (**[<▲]** **[▼▶]**); to confirm a choice the **[SET]** key must be pressed.

The **QUIT** item must be chosen to leave the **Setup Options Menu** and come back to the **Main Display Page**:

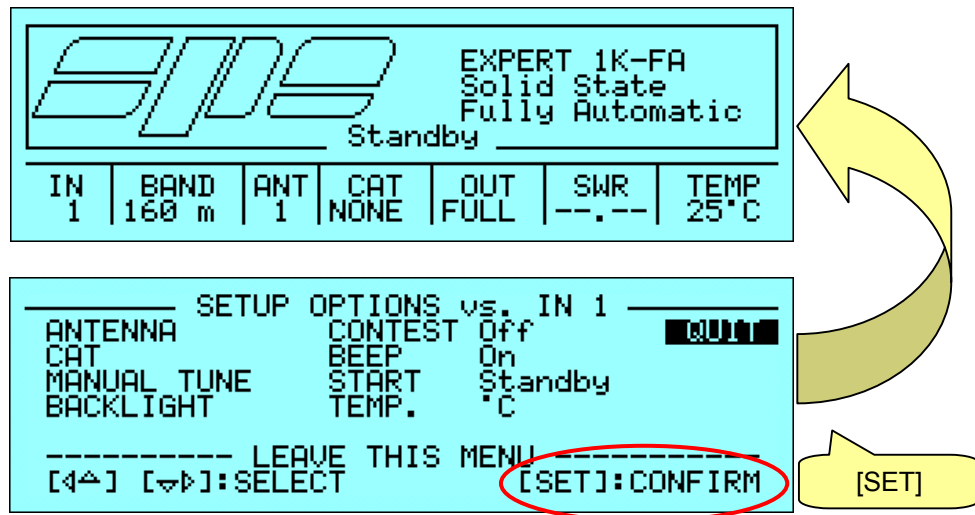

The items shown by the **Setup Options Menu** can be divided into two categories :

Selected input settings		
ANTENNA	CAT	MANUAL TUNE

Global settings				
BACKLIGHT	CONTEST	BEEP	START	TEMP.

The **Selected input settings** are used for characterizing some parameters relative to both the inputs and they are:

- **ANTENNA** for setting the proper antenna (up to a maximum of two) for every ham band relative to the selected input.
- **CAT** for setting the proper **CAT** interface relative to the selected input.
- **MANUAL TUNE** for making some manual fine-tune operations inside the tuned band relative to the selected input.

The **Global settings** perform their action over the whole system and they are:

- **BACKLIGHT** for setting the LCD backlight brightness.
- **CONTEST** for setting one of the two handling modes of the amplifier's cooling fans (CONTEST On/Off).
- **BEEP** for enabling/disabling the acoustical feedback following any keystroke coming from the amplifier's keyboard.
- **START** for setting the amplifier's startup mode (STANDBY/OPERATE) occurring after the next power-up.
- **TEMP.** for displaying the temperature measurements using either Celsius degrees (°C) or Fahrenheit degrees (°F).

18.5 SET ANTENNA Menu.

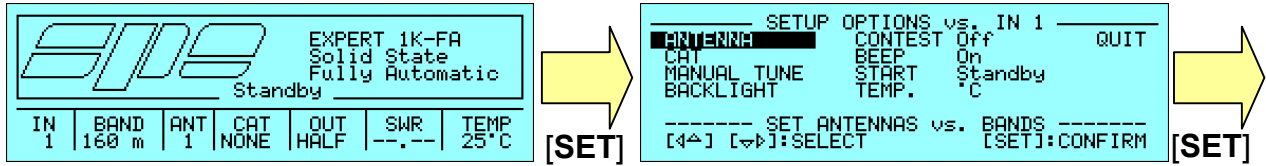

The **SET ANTENNA** is for setting the proper antennas for every ham band relative to the two inputs; the available choices are:

- 1, 2, 3, 4 corresponding to the individual output connectors mounted on the rear panel of the amplifier (**ANT1**, **ANT2**, **ANT3**, **ANT4**).
- **NO** means that there is no antenna setting for a certain ham band; this kind of setting also causes the tuning memories-to be restored to factory defaults.

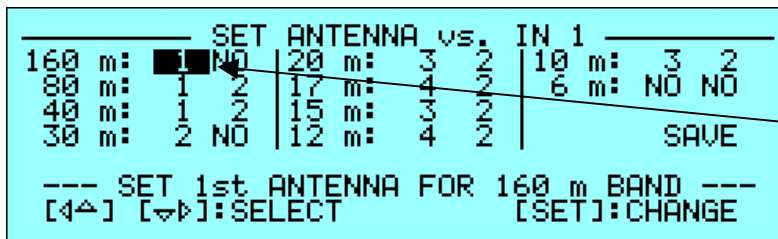

After entered the menu, the amplifier's current antenna setting is shown as the default choice (in this example is the 160 m band coupled with ANT1).

*Note: up to two different antennas can be assigned to every one of the ten ham bands; these choices are shown on the same line of the label band. Each of the two settings can be recalled while either in **STANDBY** or in **OPERATE** by simply pressing the **[ANT]** key which switches them back and forth.*

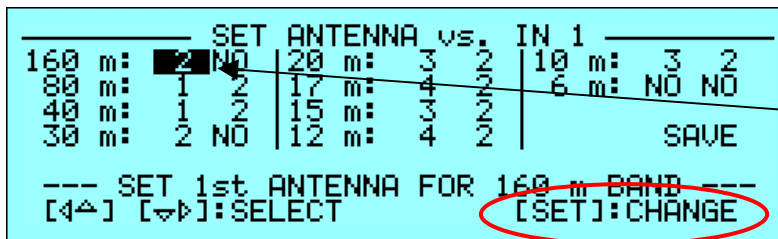

For making any change, the **[SET]** key must be repeatedly pressed until the wanted antenna value appears as the current choice (in this example ANT2).

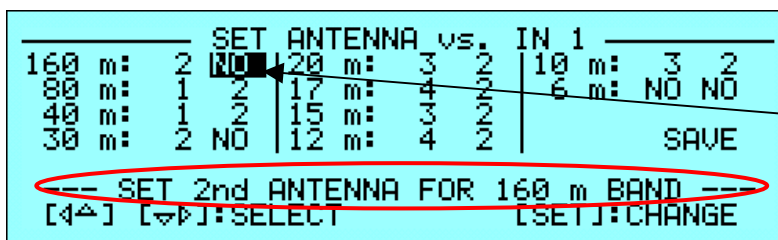

Using the selection arrow keys (**[◀▲]** **[▼▶]**), all the menu items can be selected. The contextual help line shows a short description of the current operation (in this example on the second antenna of the 160 m band).

```

----- SET ANTENNA vs. IN 1 -----
160 m: 2 NO | 20 m: 3 2 | 10 m: 3 2
80 m: 1 2 | 17 m: 4 2 | 6 m: NO NO
40 m: 1 2 | 15 m: 3 2 |
30 m: 2 NO | 12 m: 4 2 |
                                     SAVE
----- SET 1st ANTENNA FOR 80 m BAND -----
[4^] [v^]:SELECT [SET]:CHANGE
    
```

To edit the antenna setting for another band the arrow key ([◀▲] [▼▶]) must be used to select the proper choice and, then, repeat the above described procedure.

At the end of the desired setting operations, the **SAVE** option must be chosen and confirmed using the [SET] key in order to save all the data relative to the bands/antennas to the amplifier's storage memory; these settings will be available until over-written.

As a confirmation of the data save, the "**DATA STORED!**" message will appear and, then, the **Main Display Page** which restores the system in **STANDBY** mode.

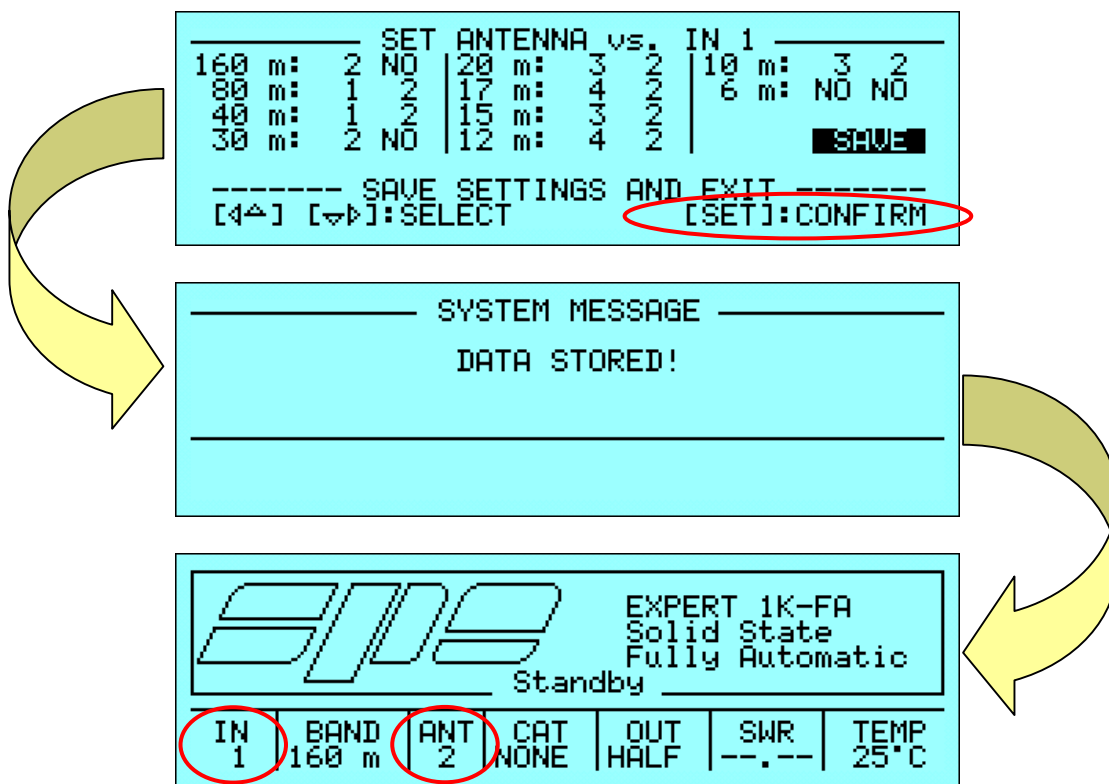

The **ANT** cell of the **Status Bar** shows, in this example, the new antenna value (**ANT 2**) which has been selected for the tuned 160 m band.

If the user wants to repeat the same kind of operation on the other input (in this example input 2), the right input must be switched using the [INPUT] key just before entering the **Setup Options Menu** and repeating the above described procedure.

The **Status Bar** always shows the updated value of the selected input.

18.6 SET CAT Menu

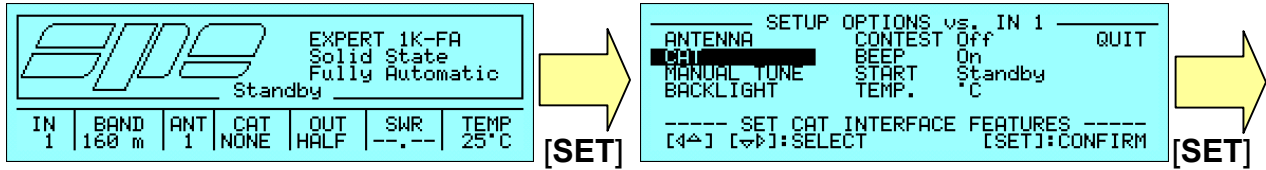

The **SET CAT** menu allows setting (or exclusion) of the **CAT** (Computer Aided Transceiver) interface. This interface, if present in the connected transceiver, allows the amplifier to read frequency and band information from the transceiver even whilst in receive mode. This means the antenna switch and ATU settings are effected even whilst in receive mode.

During transmission the internal logic bound to the frequency-counter measurements will override (eventually correct) and validate this information.

When the **SET CAT** menu is entered, the current setting is selected:

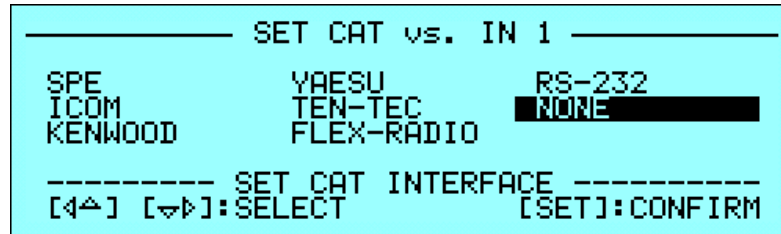

To change the current setting to a new one, select one of the proposed choices using the arrow keys ([<▲] [▼▶]) and then confirm it using the **[SET]** key:

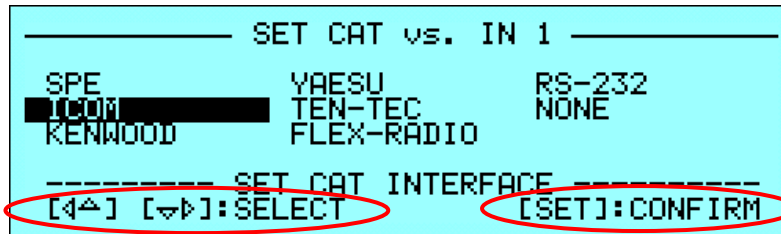

Next will be presented a new menu showing the supported models (e.g. the ICOM transceivers are equipped with two kinds of interface: CI-V and VOLTAGE_BAND): the choice selected has to be validated using the **[SET]** key:

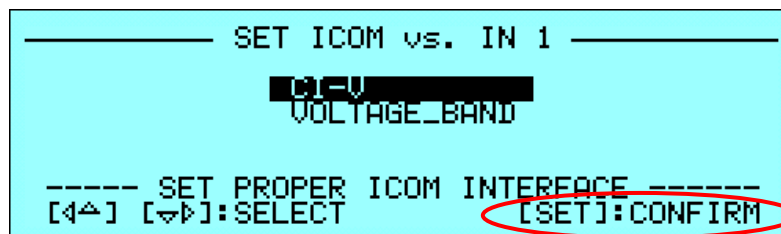

And, at the end, will be shown the menu for communication speed selection (baud-rate):

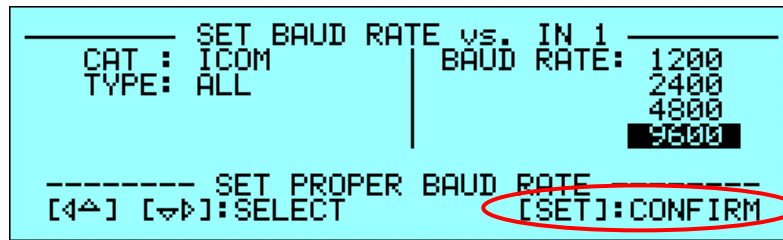

When the proper choice is made (e.g. 9600 baud) and validated pressing the **[SET]** key, the **Main Display Page** will be shown and the **Status Bar** will be updated according to the change just made.



Note: not all CAT interfaces allow all the above mentioned setting options; in the following pages the operational sequences of the various implemented options will be shown in short form.

18.7 SPE CAT Settings

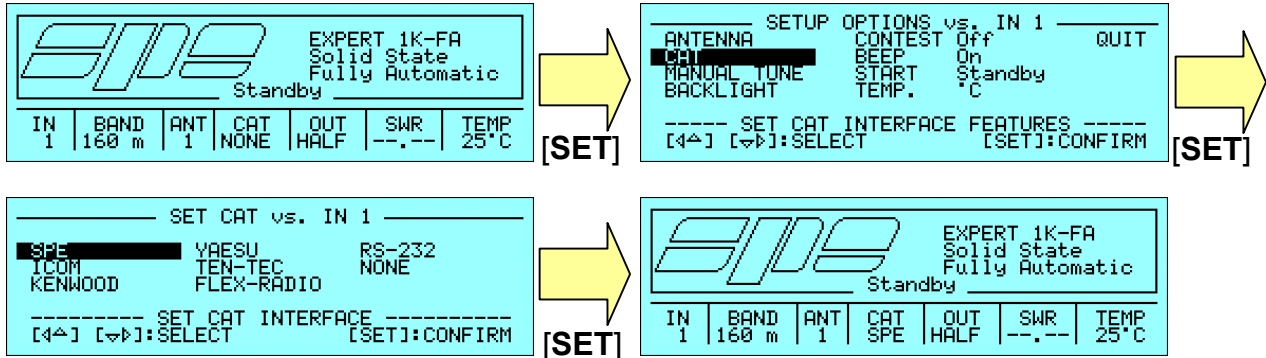

Note: SPE CAT doesn't need any baud-rate setting since it is internally fixed.

18.8 ICOM CAT Settings

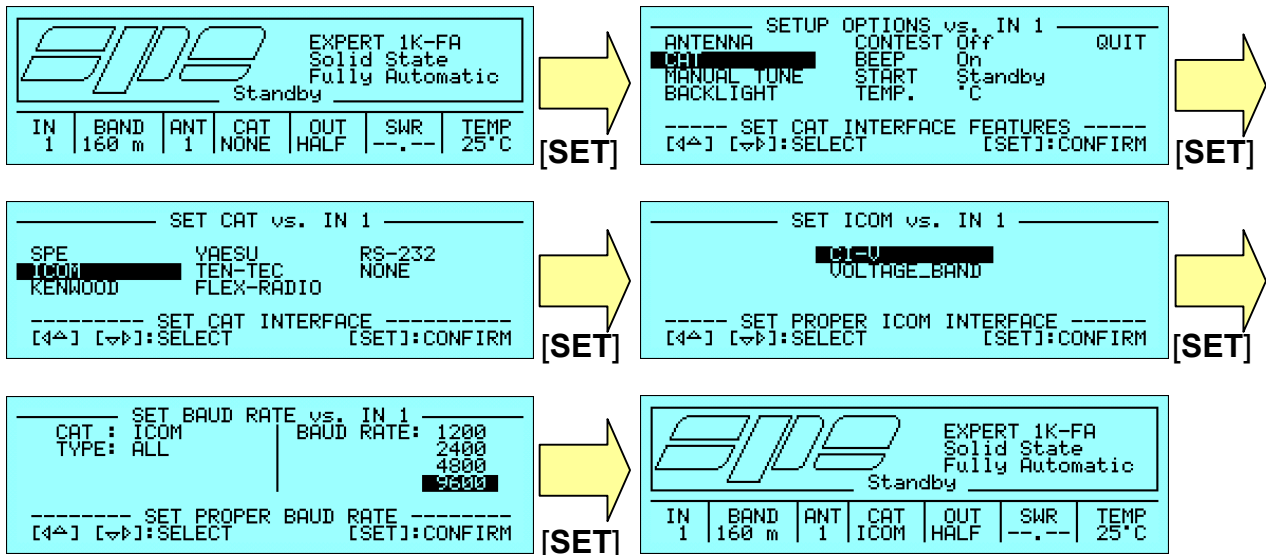

Note: when CI-V setting is made, the transceiver must be enabled in its "TRANSCEIVE ON" status following the proper setup sequence described in its reference manual.

Note: if the analog **VOLTAGE_BAND** interface is chosen, the baud-rate setting will not be shown as it is useless. In order to avoid troubles, this setting must be chosen only if the transceiver is not equipped with any **CI-V CAT** interface.

18.9 KENWOOD, ELECRAFT CAT Settings

EXPERT 1K-FA Solid State Fully Automatic Standby IN 1 BAND 160 m ANT 1 CAT NONE OUT HALF SWR --.-- TEMP 25°C	[SET]	SETUP OPTIONS vs. IN 1 ANTENNA CONTEST Off QUIT CAT BEEP On MANUAL TUNE START Standby BACKLIGHT TEMP. °C ----- SET CAT INTERFACE FEATURES ----- [4<] [↵]:SELECT [SET]:CONFIRM	[SET]
SET CAT vs. IN 1 SPE VAESU RS-232 ICOM TEN-TEC NONE KENWOOD FLEX-RADIO ----- SET CAT INTERFACE ----- [4<] [↵]:SELECT [SET]:CONFIRM	[SET]	SET BAUD RATE vs. IN 1 CAT : KENWOOD BAUD RATE: 1200 TYPE: ALL 2400 4800 9600 ----- SET PROPER BAUD RATE ----- [4<] [↵]:SELECT [SET]:CONFIRM	[SET]
EXPERT 1K-FA Solid State Fully Automatic Standby IN 1 BAND 160 m ANT 1 CAT KENWD OUT HALF SWR --.-- TEMP 25°C			

Note: KENWOOD CAT interface doesn't need any model setting.

18.10 YAESU CAT Settings

EXPERT 1K-FA Solid State Fully Automatic Standby IN 1 BAND 160 m ANT 1 CAT NONE OUT HALF SWR --.-- TEMP 25°C	[SET]	SETUP OPTIONS vs. IN 1 ANTENNA CONTEST Off QUIT CAT BEEP On MANUAL TUNE START Standby BACKLIGHT TEMP. °C ----- SET CAT INTERFACE FEATURES ----- [4<] [↵]:SELECT [SET]:CONFIRM	[SET]
SET CAT vs. IN 1 SPE VAESU RS-232 ICOM TEN-TEC NONE KENWOOD FLEX-RADIO ----- SET CAT INTERFACE ----- [4<] [↵]:SELECT [SET]:CONFIRM	[SET]	SET YAESU vs. IN 1 FT100 FT900 FT1000 MP2 FT757 8X2 FT920 FT1000 MP3 FT817/847 FT950 FT2000 FT840/890 FT1000 FT5000 FT897 FT1000 MP1 BAND_DATA ----- SET PROPER YAESU MODEL ----- [4<] [↵]:SELECT [SET]:CONFIRM	[SET]
SET BAUD RATE vs. IN 1 CAT : VAESU BAUD RATE: 1200 TYPE: FT100 2400 4800 9600 ----- SET PROPER BAUD RATE ----- [4<] [↵]:SELECT [SET]:CONFIRM	[SET]	EXPERT 1K-FA Solid State Fully Automatic Standby IN 1 BAND 160 m ANT 1 CAT VAESU OUT HALF SWR --.-- TEMP 25°C	

Note usually YAESU CAT interfaces run at 4800 baud, but, to make the right choice, it's better read the transceiver's documentation carefully. If the **BAND_DATA** interface is chosen, the baud-rate setting will not be proposed.

18.11 TEN-TEC CAT Settings

EXPERT 1K-FA Solid State Fully Automatic Standby <table border="1" style="width: 100%; border-collapse: collapse; font-size: small;"> <tr> <th>IN</th> <th>BAND</th> <th>ANT</th> <th>CAT</th> <th>OUT</th> <th>SWR</th> <th>TEMP</th> </tr> <tr> <td>1</td> <td>160 m</td> <td>1</td> <td>NONE</td> <td>HALF</td> <td>---</td> <td>25°C</td> </tr> </table>	IN	BAND	ANT	CAT	OUT	SWR	TEMP	1	160 m	1	NONE	HALF	---	25°C	[SET]	SETUP OPTIONS vs. IN 1 ANTENNA CONTEST Off QUIT CAT BEEP On MANUAL TUNE START Standby BACKLIGHT TEMP. °C ----- SET CAT INTERFACE FEATURES ----- [4←] [→]:SELECT [SET]:CONFIRM	[SET]
IN	BAND	ANT	CAT	OUT	SWR	TEMP											
1	160 m	1	NONE	HALF	---	25°C											
SET CAT vs. IN 1 SPE VAESU RS-232 ICOM TEN-TEC NONE KENWOOD FLEX-RADIO ----- SET CAT INTERFACE ----- [4←] [→]:SELECT [SET]:CONFIRM	[SET]	SET TEN-TEC vs. IN 1 MINI-UII JUPITER ORION 1/11 ARGONAUT V ----- SET PROPER TEN-TEC MODEL ----- [4←] [→]:SELECT [SET]:CONFIRM	[SET]														
EXPERT 1K-FA Solid State Fully Automatic Standby <table border="1" style="width: 100%; border-collapse: collapse; font-size: small;"> <tr> <th>IN</th> <th>BAND</th> <th>ANT</th> <th>CAT</th> <th>OUT</th> <th>SWR</th> <th>TEMP</th> </tr> <tr> <td>1</td> <td>160 m</td> <td>1</td> <td>T-TEC</td> <td>HALF</td> <td>---</td> <td>25°C</td> </tr> </table>	IN	BAND	ANT	CAT	OUT	SWR	TEMP	1	160 m	1	T-TEC	HALF	---	25°C			
IN	BAND	ANT	CAT	OUT	SWR	TEMP											
1	160 m	1	T-TEC	HALF	---	25°C											

Nota: TEN-TEC transceivers come with their respective baud-rate setting fixed by default, so the baud-rate menu is not proposed since it is useless.

18.12 FLEX-RADIO CAT Settings

EXPERT 1K-FA Solid State Fully Automatic Standby <table border="1" style="width: 100%; border-collapse: collapse; font-size: small;"> <tr> <th>IN</th> <th>BAND</th> <th>ANT</th> <th>CAT</th> <th>OUT</th> <th>SWR</th> <th>TEMP</th> </tr> <tr> <td>1</td> <td>160 m</td> <td>1</td> <td>NONE</td> <td>HALF</td> <td>---</td> <td>25°C</td> </tr> </table>	IN	BAND	ANT	CAT	OUT	SWR	TEMP	1	160 m	1	NONE	HALF	---	25°C	[SET]	SETUP OPTIONS vs. IN 1 ANTENNA CONTEST Off QUIT CAT BEEP On MANUAL TUNE START Standby BACKLIGHT TEMP. °C ----- SET CAT INTERFACE FEATURES ----- [4←] [→]:SELECT [SET]:CONFIRM	[SET]
IN	BAND	ANT	CAT	OUT	SWR	TEMP											
1	160 m	1	NONE	HALF	---	25°C											
SET CAT vs. IN 1 SPE VAESU RS-232 ICOM TEN-TEC NONE KENWOOD FLEX-RADIO ----- SET CAT INTERFACE ----- [4←] [→]:SELECT [SET]:CONFIRM	[SET]	SET BAUD RATE vs. IN 1 CAT : FLEX-RADIO BAUD RATE: 1200 TYPE: ALL 2400 4800 9600 ----- SET PROPER BAUD RATE ----- [4←] [→]:SELECT [SET]:CONFIRM	[SET]														
EXPERT 1K-FA Solid State Fully Automatic Standby <table border="1" style="width: 100%; border-collapse: collapse; font-size: small;"> <tr> <th>IN</th> <th>BAND</th> <th>ANT</th> <th>CAT</th> <th>OUT</th> <th>SWR</th> <th>TEMP</th> </tr> <tr> <td>1</td> <td>160 m</td> <td>1</td> <td>FLEX</td> <td>HALF</td> <td>---</td> <td>25°C</td> </tr> </table>	IN	BAND	ANT	CAT	OUT	SWR	TEMP	1	160 m	1	FLEX	HALF	---	25°C			
IN	BAND	ANT	CAT	OUT	SWR	TEMP											
1	160 m	1	FLEX	HALF	---	25°C											

*Note FlexRadio Cat interface doesn't need any model characterization. Its main feature is it needs some presets which have necessarily to be fixed when in **OPERATE Mode**. If interested, read carefully the section "**OPERATE Mode and FLEX-RADIO CAT interface**" detailed later.*

18.13 RS-232 CAT Settings

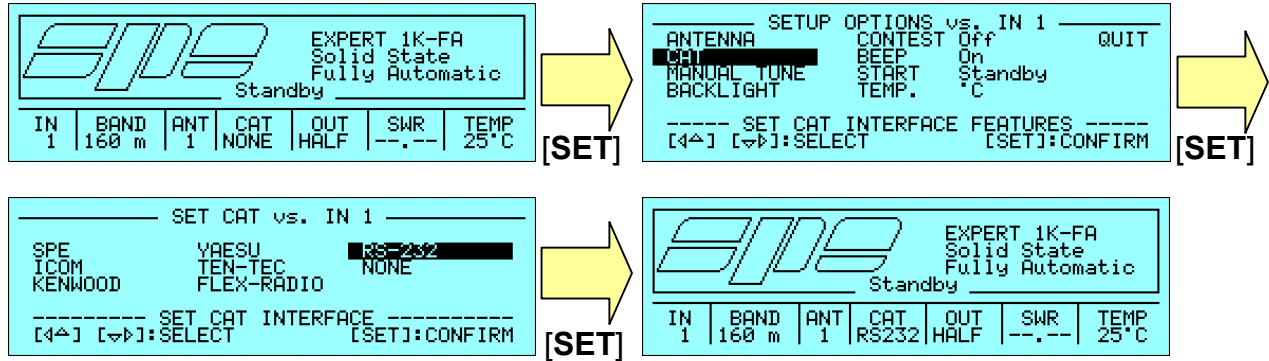

Note: RS-232 CAT interface is an internal link connected to the serial interface connector used for EXPERT's remotization that has to be made using a suitable PC software. Further details concerning this kind of interface can be found by consulting the document "Communication Protocol Specifications Rev. 2.0" freely available from the EXPERT linear amplifier's website (<http://www.linear-amplifier.com>).

18.14 NO CAT Settings

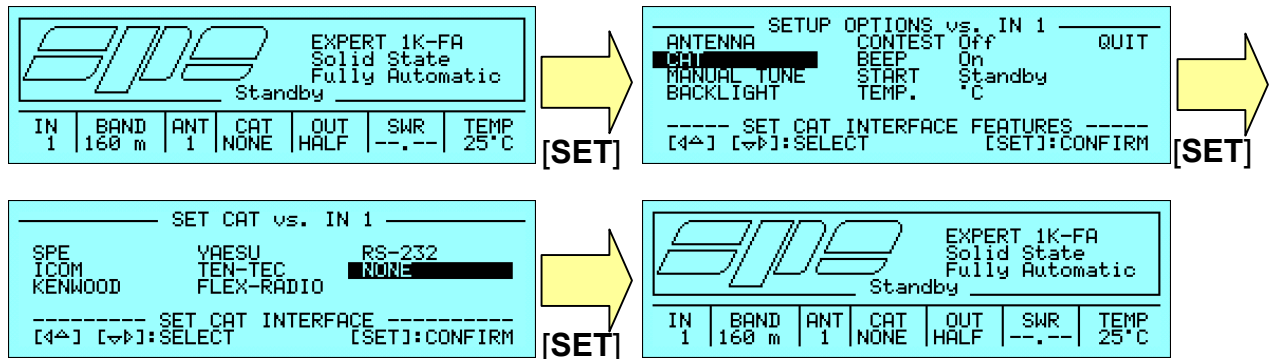

Note: this choice disables any kind of CAT interface and is the right one to choose when the used transceiver is not inside the supported models and, then, this link cannot be used.

When either in **STANDBY** or **OPERATE** mode, at any time a short report about the CAT settings related to the two inputs can be obtained by simply pressing the [**CAT**] key and keeping it held down; an info display screen with a short summary, like the following, will be shown in which it can be seen that:

- An ICOM CAT CI-V interface running at 9600 baud is set for Input 1
- A generic KENWOOD CAT interface running at 9600 baud is set for Input 2

IN 1				IN 2			
CAT :	ICOM			CAT :	KENWOOD		
TYPE:	CI-V			TYPE:	ALL		
BAUD:	9600			BAUD:	9600		
IN	BAND	ANT	CAT	OUT	SWR	TEMP	
1	160 m	1	ICOM	HALF	---.---	25°C	

The [**CAT**] key has another informative functionality. It is used to show the firmware release version too: by shortly releasing it and pressing it again a new display info page, like the following, will be shown while it is held down:

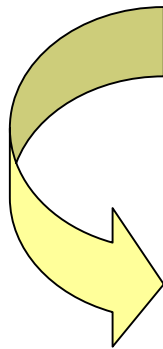

SYSTEM INFO						
EXPERT 1K-FA Rel. 07_07_07_F						
CE/FCC COMPLIANT SECOND SERIES						
IN	BAND	ANT	CAT	OUT	SWR	TEMP
1	160 m	1	ICOM	HALF	---.---	25°C

			EXPERT 1K-FA			
			Solid State			
			Fully Automatic			
Standby						
IN	BAND	ANT	CAT	OUT	SWR	TEMP
1	160 m	1	ICOM	HALF	---.---	25°C

By releasing the [**CAT**] key, the original display page will be shown again (in this example the **Main Display Page**).

18.15 MANUAL TUNE Display Page.

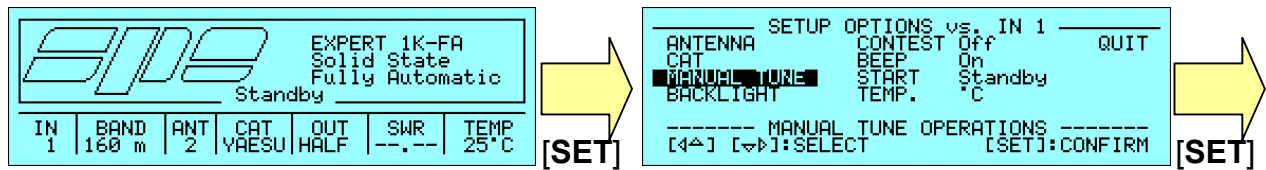

This display page is for making some small adjustments to the L-C values of the automatic tuner; this “fine tune” operation could be necessary either if the user cannot reach a good match using the automatic tuning or if he simply wants to apply some manual variations to the current settings.

In the following picture is shown an example of some settings of the **Manual Tune Display Page** together with the **Status Bar** readouts that allow total control of the situation; it can easily be seen that Input 1 is used in the 160 m band with antenna 2 connected and with the sub-band 6 (1.840 MHz..1.850 MHz) switched.

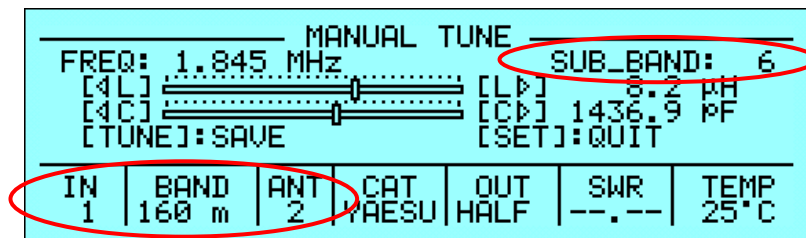

The two “sliders” L-C (Lout, Cout) position is:

- 8.2 uH for Lout
- 1436.9 pF for Cout

Using the following keys:

- [←L] [L→] the resulting value of Lout may be changed (-/+)
- [←C] [C→] the resulting value of Cout may be changed (-/+)

All the changes are shown using the “sliders” graphics shown on the display page:

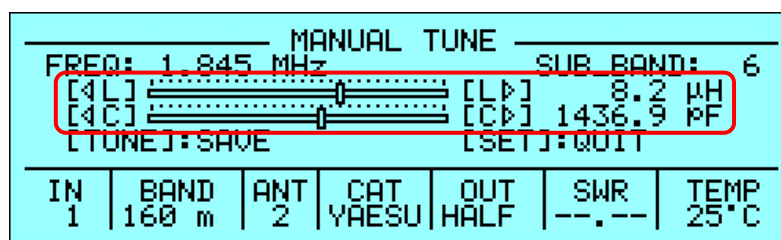

When in TX mode the frequency readout and the SWR readout displayed in the Status Bar are simultaneously updated.

MANUAL TUNE						
FREQ: 1.845 MHz			SUB_BAND: 6			
[M]	[L>]		[L>]		7.9 μ H	
[C]	[C]		[C]		1486.2 PF	
[TUNE]:SAVE			[SET]:QUIT			
IN	BAND	ANT	CAT	OUT	SWR	TEMP
1	160 m	2	YAESU	HALF	1.03	25°C

If the applied manual changes are satisfactory, this configuration can be saved (inside the non-volatile memory related to sub-band 6) using the [TUNE] key. By pressing the [SET] key the original tuner setting can be restored instead (i.e. the one before the changes).

In any way there is a return to the **Main Display Page**.

EPE						
			EXPERT 1K-FA			
			Solid State			
			Fully Automatic			
Standby						
IN	BAND	ANT	CAT	OUT	SWR	TEMP
1	160 m	2	YAESU	HALF	---	25°C

18.16 BACKLIGHT Display Page.

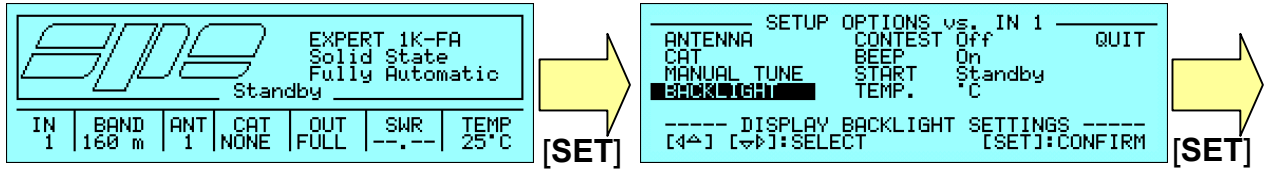

This display page allows the backlight setting of the LCD display mounted of the front panel of the amplifier using the arrow keys ([<▲] [▼>]).

The amount set is displayed by the slider setting.

To complete the operation and save the setting, press the [SET] key.

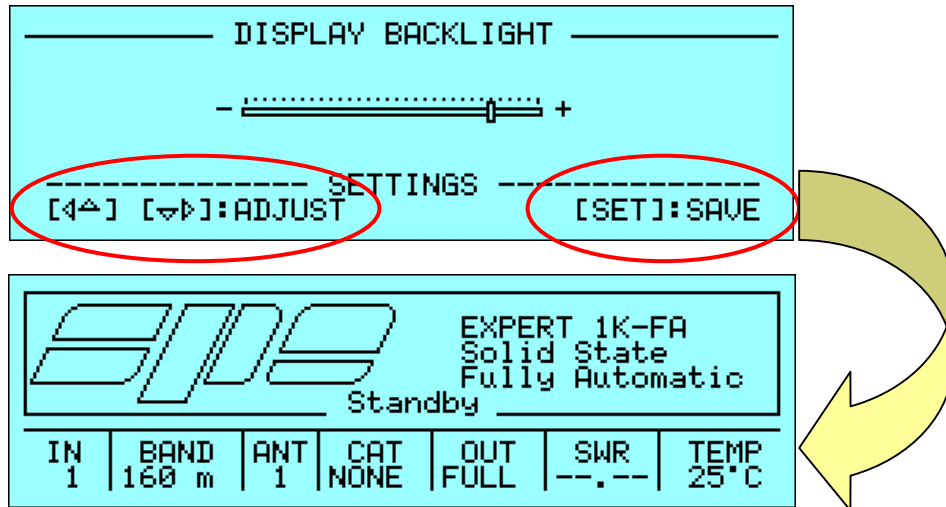

18.17 CONTEST Settings.

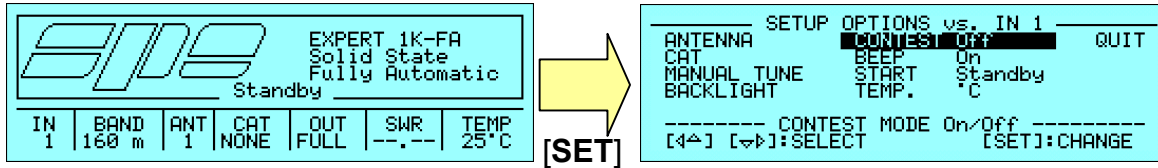

This menu item allows setting of the fan's speed.

In detail:

- **Contest Off** the three speeds are set at the following thresholds:
 - 40 °C (104 °F) On; 37 °C (98.6 °F) Off
 - 70 °C (158 °F) On; 67 °C (152.6 °F) Off
 - 83 °C (181,4 °F) On; 80 °C (176 °F) Off
- **Contest On** the three speeds are set at the following thresholds:
 - Permanently active.
 - 60 °C (140 °F) On; 57 °C (134.6 °F) Off
 - 75 °C (167 °F) On; 72 °C (161.6 °F) Off

To make these changes, press the **[SET]** key:

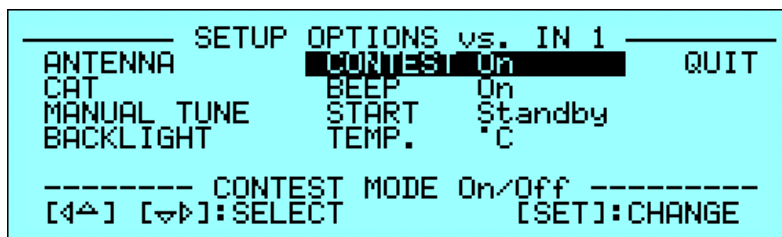
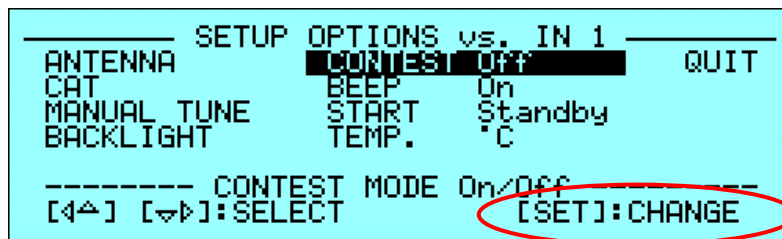

To leave this menu, the **QUIT** option has to be chosen and then confirmed using the **[SET]** key.

18.18 BEEP Settings.

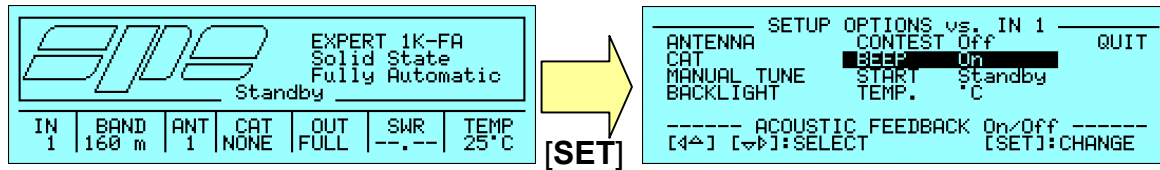

This menu item allows you to select if the beep is **On** or **Off** following any keystroke coming from the linear amplifier front panel keyboard.

To make these changes, press the **[SET]** key:

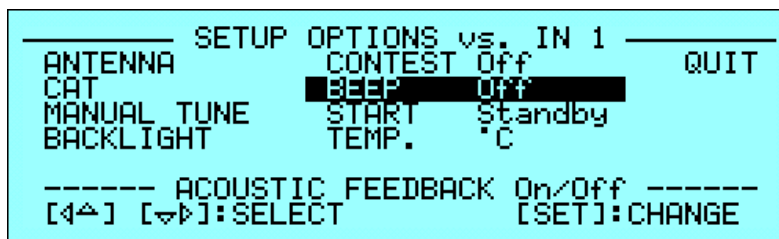
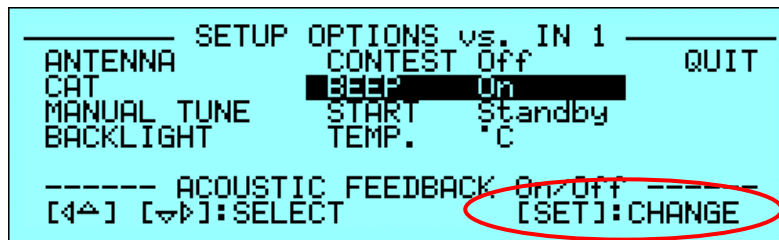

To leave this menu, the **QUIT** option has to be chosen and then confirmed using the **[SET]** key.

18.19 START Settings.

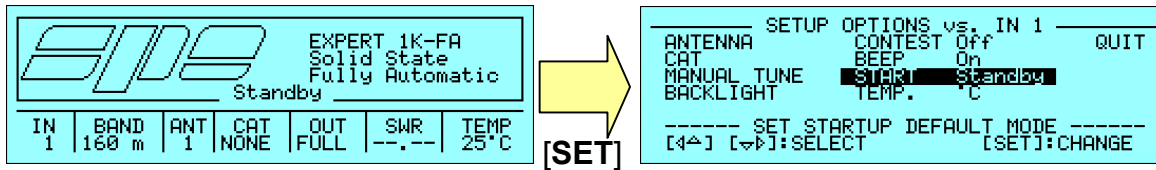

This menu item allows to choose, between the two possible **Standby/Operate** states:

- **Standby** turns the amplifier in the **Main Display Page** after its power-up. From this display page the user can perform all the operations described till now.
- **Operate** turns the amplifier in the **OPERATE Mode** (that will be described later) after its power-up. From this display page the user can, eventually, go to the **Main Display Page**.

To make these changes, press the **[SET]** key:

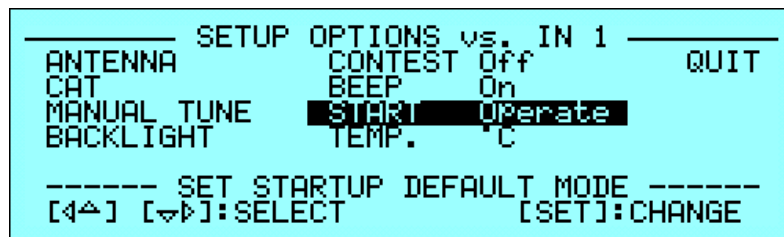
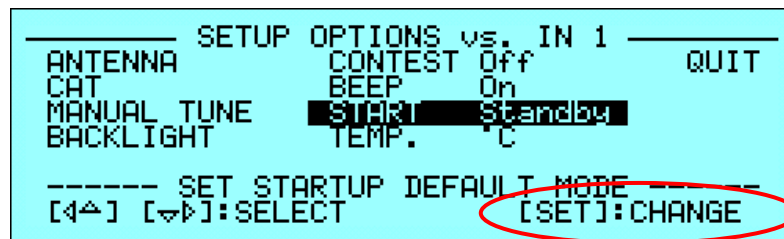

To leave this menu, the **QUIT** option has to be chosen and then confirmed using the **[SET]** key.

Note: this setting will be applied after the next power-up of the linear amplifier and will remain till any eventual future changing.

18.20 TEMP Settings.

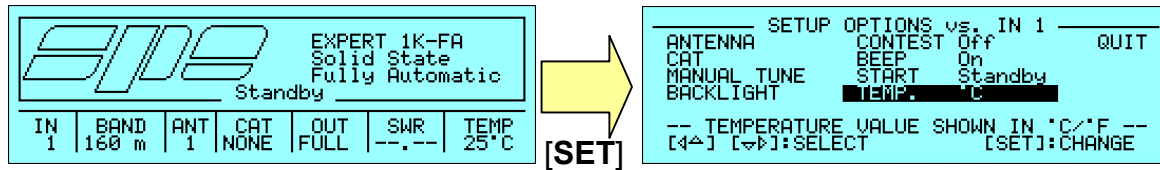

This menu item allows to choose, between the two possible °C/°F (Celsius degrees, Fahrenheit degrees), the temperature readout inside the **Status Bar**. This value is taken from the internal heatsink.

To make these changes, press the [SET] key:

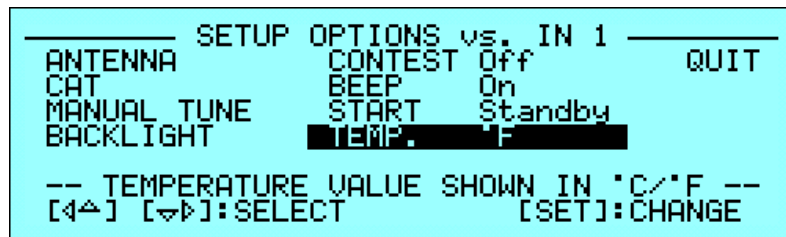
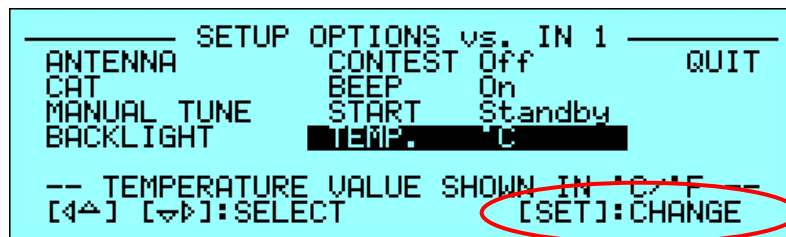

To leave this menu, the **QUIT** option has to be chosen and then confirmed using the [SET] key.

18.21 OPERATE Mode.

In this working mode, the linear amplifier power circuitry is supplied and enabled. It can be activated, from the **Main Display Page**, either by pressing the **[OPERATE]** key located of the front panel or by previously setting, from the **SETUP OPTIONS** menu, the **START Operate** option.

There are two possible **OPERATE Mode** display pages:

- displaying of **PA OUT** (output power) + **I PA** (power-supply source current)
- displaying of **PW REV** (reverse power) + **V PA** (power-supply source voltage)
- NB – The PW REV thus displayed is the reflected power before the low pass filter, including harmonic power reflected by the filter. It is NOT the reflected power as measured at the antenna output.

The **[DISPLAY]** key allows to switch back and forth these two display pages and to make a proper context change.

When entering the **OPERATE Mode**, the default display page is the one left either the last time before the return to the **Main Display Page** or before a “soft shutdown” using the **[OFF]** key.

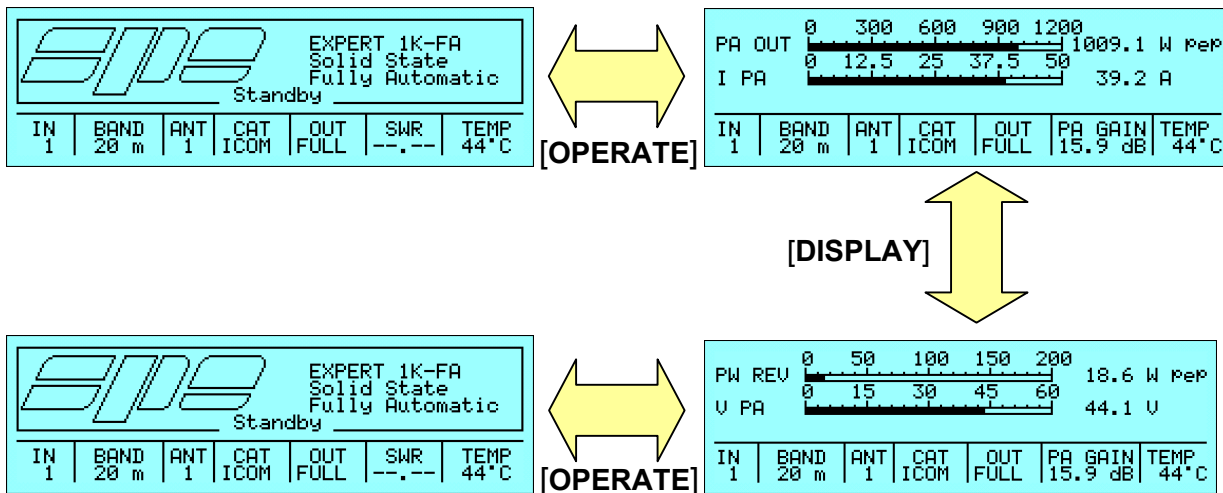

In any way it is allowed to return to the Main Display Page pressing the **[OPERATE]** key again.

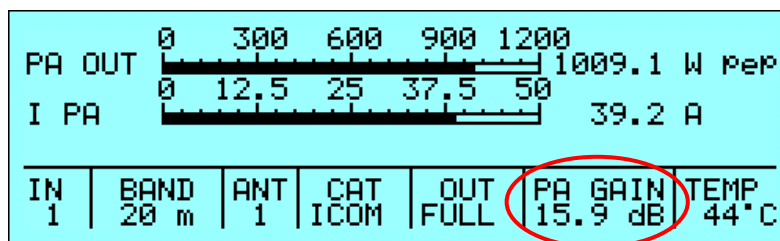

*Note: while in **OPERATE Mode**, the SWR readout inside the Status Bar is substituted with the power amplifier gain value (**PA GAIN**) expressed in dB and according to the following formula: $PA\ GAIN(dB) = 10 \cdot \log(PA_OUT/PW_IN)$.*

As previously written, while in **OPERATE Mode** two distinct display pages can be obtained and they allow to control, together with the Status Bar, the full working of the linear amplifier. To switch back and forth the two display pages, press the **[DISPLAY]** key.

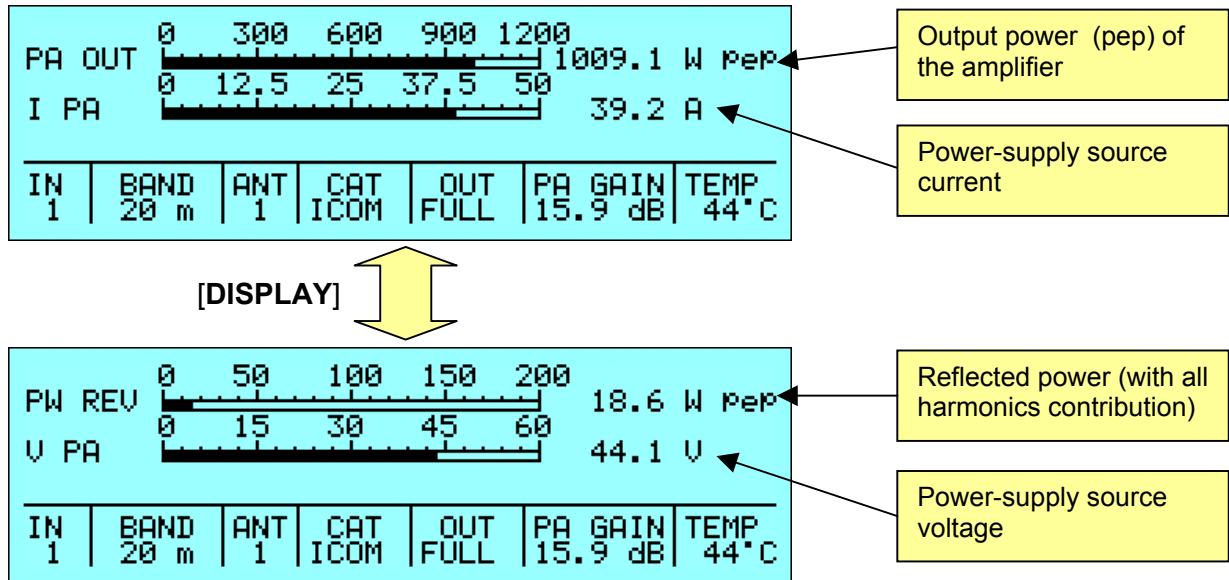

The output power, reflected power, supply voltage and supply current are displayed, other than in numerical form, in graphical form too by means of proper “level bars” provided with a “peak hold” embedded function (about 1 s) which is useful for better evaluating the measurements variations.

While in **OPERATE Mode** the following switchings are possible:

- Input selection – Pressing the **[INPUT]** key there is a switching between the two inputs; the same result can be obtained driving the two **RELAY** inputs placed on the rear panel of the amplifier itself (by pressing the respective **PTT** keys of the two connected transceivers).
- Manual band selection – Pressing the **[◀BAND]** and **[BAND▶]** keys the working tuning band can be selected if there is not any CAT setting (CAT = NONE).
- Antenna switching (one of two) for a given band – Pressing the **[ANT]** key there is an antenna switching between the two presets stored for the selected band and a subsequent variation of the tuner settings.
- Power mode setting – Pressing **[POWER]** key, the amplifier’s power management is switched between **HALF** (half power mode) and **FULL** (full power mode).



The complete readouts of the early mentioned settings are displayed inside the **Status Bar** as shown in the above reproduced page detail.

18.22 OPERATE Mode and FLEX-RADIO CAT interface.

When FlexRadio CAT interface is set, there must be programmed the maximum power limits for the transceiver in order to avoid the EXPERT's overdrive protection system intervention (refer to the **Diagnostics** section); this is a very important operation since FlexRadio transceivers don't have any traditional ALC input.

These settings have to be done while in **OPERATE Mode** according to the followings.

For every ham band two settings are allowed (storage memories):

- One setting for HALF mode.
- One setting for FULL mode.

The following table shows an overall vision of these settings:

Band	160 m	80 m	40 m	30 m	20 m	17 m	15 m	12 m	10 m	6 m
HALF	Preset Half	Preset Half	Preset Half	Preset Half	Preset Half	Preset Half	Preset Half	Preset Half	Preset Half	Preset Half
FULL	Preset Full	Preset Full	Preset Full	Preset Full	Preset Full	Preset Full	Preset Full	Preset Full	Preset Full	Preset Full

The user has to set, for every band of interest, the power limit concerning the input power limitation (Power Control) using the keyboard and the display of the linear amplifier.

To make this, obtain a proper band selection using the CAT interface and, without leaving the RX mode, press one of the arrow keys ([◀▲] [▼▶]) from the EXPERT's keyboard; a report value having the format "[PC=xxx]" (where xxx is a numerical value having a range from 000 to 100 which represents the transceiver's upper power limit expressed in percentage) will appear just over the **BAND** label of the **Status Bar**.

This value is relative to the tuned band and to the selected power mode (HALF/FULL).

In the following picture is shown (as an example) a **Power Control** equal to 31% in the **20 m** band and in **FULL** power mode:

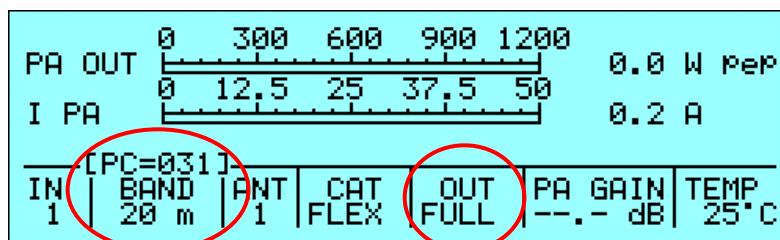

Pressing the arrow keys ([◀▲] [▼▶]) this value can be decremented/incremented until it reaches the requested value; at the operation completion a time-out period (about 3 seconds) must be awaited to expire for the "[PC=xxx]" indication disappearing and for, eventually, proceed to another adjusting using the same rules. The Power Control settings are global since they applies to both inputs.

In the following picture can be seen, as an example, the **Power Control (15%)** setting relative to the same band (**20 m**), but using the **HALF** mode selection instead.

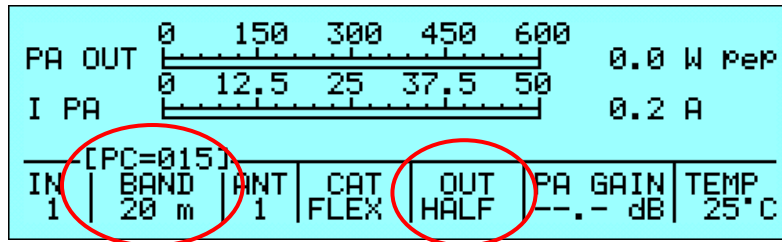

Once adjusted the proper preset, go to TX mode (RTTY, CW) to verify the output power

ATTENTION! It is strongly recommended to start with a low preset value (e.g. 10) and progressively increasing it; this is to avoid the linear overdriving.

The output power levels to reach are about 900 W (FULL mode) e 500 W (HALF mode).

The following empty table could be useful as a template for the FlexRadio user's Power Control presettings.

Band	160 m	80 m	40 m	30 m	20 m	17 m	15 m	12 m	10 m	6 m
HALF										
FULL										

18.23 Diagnostics.

During normal working, the system performs a continuous monitoring of some measurements directly acquired from certain internal test-points; among the most important there are the ones related to the power-supply unit behaviour.

When a dangerous situation is going to happen, a “serious” alarm message is raised and the working mode is switched from **OPERATE** to **STANDBY**.

The user can either immediately restore the **Main Display Page** by pressing the **[DISPLAY]** key or wait for the visual alarm time-out expiration (about 10 seconds).

In the following picture is shown, as an example, the case of a power-supply unit trouble (the power-supply voltage level is fallen below the programmed threshold) while in **OPERATE** mode:

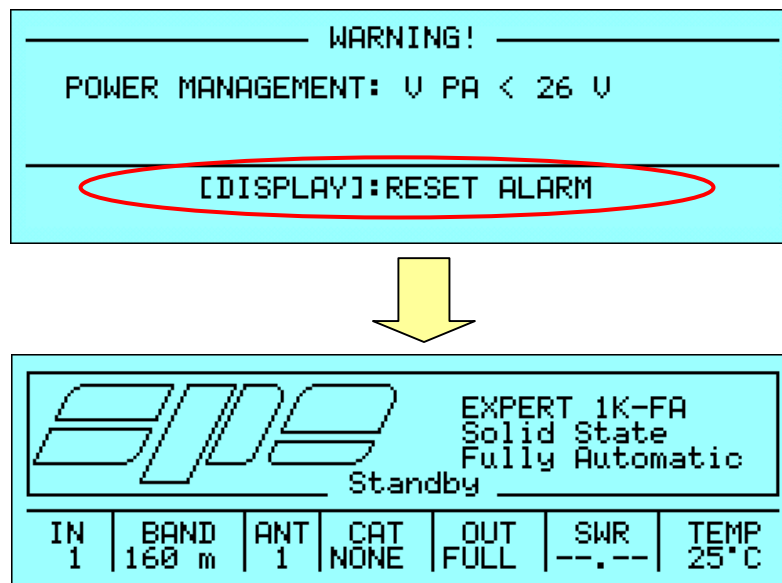

After having restored from an alarm message, the **Alarm History** report can be viewed and browsed as described in the relative section.

The following table shows all the system's alarm messages that are recorded in the **Alarm History** stack:

MESSAGE	MEANING
POWER MANAGEMENT: V PA < 20 V	HALF mode: supply voltage level < 20 V
POWER MANAGEMENT: V PA < 26 V	FULL mode: supply voltage level < 26 V
POWER MANAGEMENT: V PA > 50 V	HALF/FULL mode: supply voltage level > 50 V
POWER MANAGEMENT: I PA > 40 A	HALF mode: supply sourced current > 40 A
POWER MANAGEMENT: I PA > 50 A	FULL mode: supply sourced current > 50 A
P.A. MANAGEMENT: OVER DRIVING	Amplifier over driving
P.A. MANAGEMENT: PA PROTECTION	Internal hardware protections intervention
P.A. MANAGEMENT: PW REV > 300 W	Reflected power > 300 W
OVER TEMPERATURE: TEMP > 90 °C	Heatsink temperature > 90 °C (194 °F)

While the following table shows all the dynamic warning messages that are not recorded in the **Alarm History** stack:

MESSAGE	MEANING
160 m ANTENNA NOT AVAILABLE	Antenna not available for 160 m band
80 m ANTENNA NOT AVAILABLE	Antenna not available for 160 m band
40 m ANTENNA NOT AVAILABLE	Antenna not available for 160 m band
30 m ANTENNA NOT AVAILABLE	Antenna not available for 160 m band
20 m ANTENNA NOT AVAILABLE	Antenna not available for 160 m band
17 m ANTENNA NOT AVAILABLE	Antenna not available for 160 m band
15 m ANTENNA NOT AVAILABLE	Antenna not available for 160 m band
12 m ANTENNA NOT AVAILABLE	Antenna not available for 160 m band
10 m ANTENNA NOT AVAILABLE	Antenna not available for 160 m band
6 m ANTENNA NOT AVAILABLE	Antenna not available for 160 m band
BAND NOT PERMITTED	Out of band signalling
HIGH REFLECTED POWER	In OPERATE mode reflected power > 250 W

19. TABLE

BAND TABLE, SUB-BAND, CENTRAL FREQUENCY SUB-BAND

160 m	[0] 1785	[1] 1795	[2] 1805	[3] 1815	[4] 1825	[5] 1835
	[6] 1845	[7] 1855	[8] 1865	[9] 1875	[10] 1885	[11] 1895
	[12] 1905	[13] 1915	[14] 1925	[15] 1935	[16] 1945	[17] 1955
	[18] 1965	[19] 1975	[20] 1985	[21] 1995	[22] 2005	[23] 2015
80 m	[24] 3470	[25] 3490	[26] 3510	[27] 3530	[28] 3550	[29] 3570
	[30] 3590	[31] 3610	[32] 3630	[33] 3650	[34] 3670	[35] 3690
	[36] 3710	[37] 3730	[38] 3750	[39] 3770	[40] 3790	[41] 3810
	[42] 3830	[43] 3850	[44] 3870	[45] 3890	[46] 3910	[47] 3930
	[48] 3950	[49] 3970	[50] 3990	[51] 4010	[52] 4030	
40 m	[53] 6963	[54] 6988	[55] 7013	[56] 7038	[57] 7063	[58] 7088
	[59] 7113	[60] 7138	[61] 7163	[62] 7188	[63] 7213	[64] 7238
	[65] 7263	[66] 7288	[67] 7313	[68] 7338		
30 m	[69] 10075	[70] 10125	[71] 10175			
20 m	[72] 13975	[73] 14025	[74] 14075	[75] 14125	[76] 14175	[77] 14225
	[78] 14275	[79] 14325	[80] 14375			
17 m	[81] 18075	[82] 18125	[83] 18165			
15 m	[84] 20975	[85] 21025	[86] 21075	[87] 21125	[88] 21175	[89] 21225
	[90] 21275	[91] 21325	[92] 21375	[93] 21425	[94] 21475	
12 m	[95] 24891	[96] 24963	[97] 25038			
10 m	[98] 27950	[99] 28050	[100] 28150	[101] 28250	[102] 28350	[103] 28450
	[104] 28550	[105] 28650	[106] 28750	[107] 28850	[108] 28950	[109] 29050
	[110] 29150	[111] 29250	[112] 29350	[113] 29450	[114] 29550	[115] 29650
	[116] 29750					
6 m	[117] 49750	[118] 50250	[119] 50750	[120] 51250	[121] 51750	[122] 52250
	[123] 52750	[124] 53250	[125] 53750	[126] 54250		

Note: [sub-band] Central frequency KHz

20. WARRANTY

SPE warrants to the original purchaser that this product shall be free from defects or workmanship.

SPE warrants for two (2) years from the date of original purchaser that will provide free of charge all parts and labor necessary to correct defects in material or workmanship. The purchaser has to pay only the cost of shipping for warranty work.

The warranty repair service must be obtained from your dealer where the amplifier was purchased and that dealer is responsible for the warranty. In the event that the dealer no longer is present in the market, or if the purchaser moves into another area, the SPE will be responsible for warranty service. The costs of shipping to and from SPE will then be paid by the customer. Any repair requests to other dealers will be subject to specific direct negotiations between the customer and the dealer.

In order to do not lose the warranty service, the original purchaser must:

- 1) Complete and send to SPE, not over 30 days from the date of purchase, the warranty registration card with a document certifying the date of purchase (eg invoice, receipt, etc.).
- 2) Notify SPE or its nearest authorized service facility, immediately the defect is discovered sending the properly completed REPAIR FORM.

The warranty does not apply to any defect that SPE determines is due to:

- a) Improper maintenance or repair by persons not authorised by SPE to carry out such work, including the installation of parts or accessories that do not conform to the quality and specifications of the original parts.
- b) Misuse, abuse, neglect or improper installation, user's manual non-observance.
- c) Carelessness, accidental or intentional damage.

SPE warranties aforesaid items only, and the purchaser shall have no remedy and no claim for incidental or consequential damages.

Particular agreements between retailer and purchaser or particular obligations imposed in other countries are matters for the local retailer and not for SPE.

SPE recommends you record this information:

- Model of the amplifier
- Serial number
- Date of purchase
- Name and address of the retailer
- Date of mailing of the Warranty Card.

REPAIR FORM

MODEL SERIAL NUMBER DATE

CONNECTION STATE AT THE MOMENT OF THE BREAKDOWN

TRANSCEIVER MODEL

CAT CONNECTION YES NO

IF YES INDICATE THE ITEM HEADING IN THE USER'S MANUAL

IF NO BAND DATA INTERFACE YES

BAND CONTROL VOLTAGE INTERFACE YES

ANY LINK? YES

THE ALC WAS CONNECTED? YES NO

WAS THE DRIVING POWER OF THE TRANSCEIVER SET AT THE MAXIMUM LEVEL? YES NO

IF 'NO', WHAT POWER OUTPUT WAS SET?

ON WHICH BAND DID THE FAULT HAPPEN?

DID YOU CHANGE BANDS / ANTENNA IMMEDIATELY BEFORE THE FAULT HAPPENED? YES NO

PLEASE WRITE THE TRANSMISSION MODE: SSB CW QSK DIGITAL MODE/FM AM

FOR HOW LONG BEFORE THE FAILURE DID YOU SWITCH ON THE AMPLIFIER?

THE AMPLIFIER WAS IN THE: HALF POWER FULL POWER

WHICH WAS THE INPUT USED? INPUT 1 INPUT 2

WHICH WAS THE TEMPERATURE OF THE AMPLIFIER ?

WHAT FAULT INFORMATION WAS DISPLAYED ON THE LCD?

WHICH WAS THE MAINS VOLTAGE AT THE MOMENT OF THE BREAKDOWN?

OTHER INFORMATION:
.....
.....
.....

SPACE FOR THE REPAIRER

REPAIRER DATE OF ARRIVAL

NOTES ABOUT THE AMPLIFIER WHEN YOU RECEIVED IT
.....
.....

PARTS REPLACED
.....
.....
.....

DATE OF TESTS
.....

SIGNATURE OF THE REPAIRER
.....

SPE s.r.l.

Via di Monteverde, 33 00152 Rome (Italy)

Tel. +390658209429

Fax. +390658209647

E-mail: info@linear-amplifier.comWebsite: <http://www.linear-amplifier.com>